



TYPICAL

GK0056D SERIES

DIRECT DRIVE HIGH SPEED CHAINSTITCHER MACHINE
INSTRUCTION BOOK/PARTS CATALOGUE

1. ARM BED AND ITS ACCESSORIES

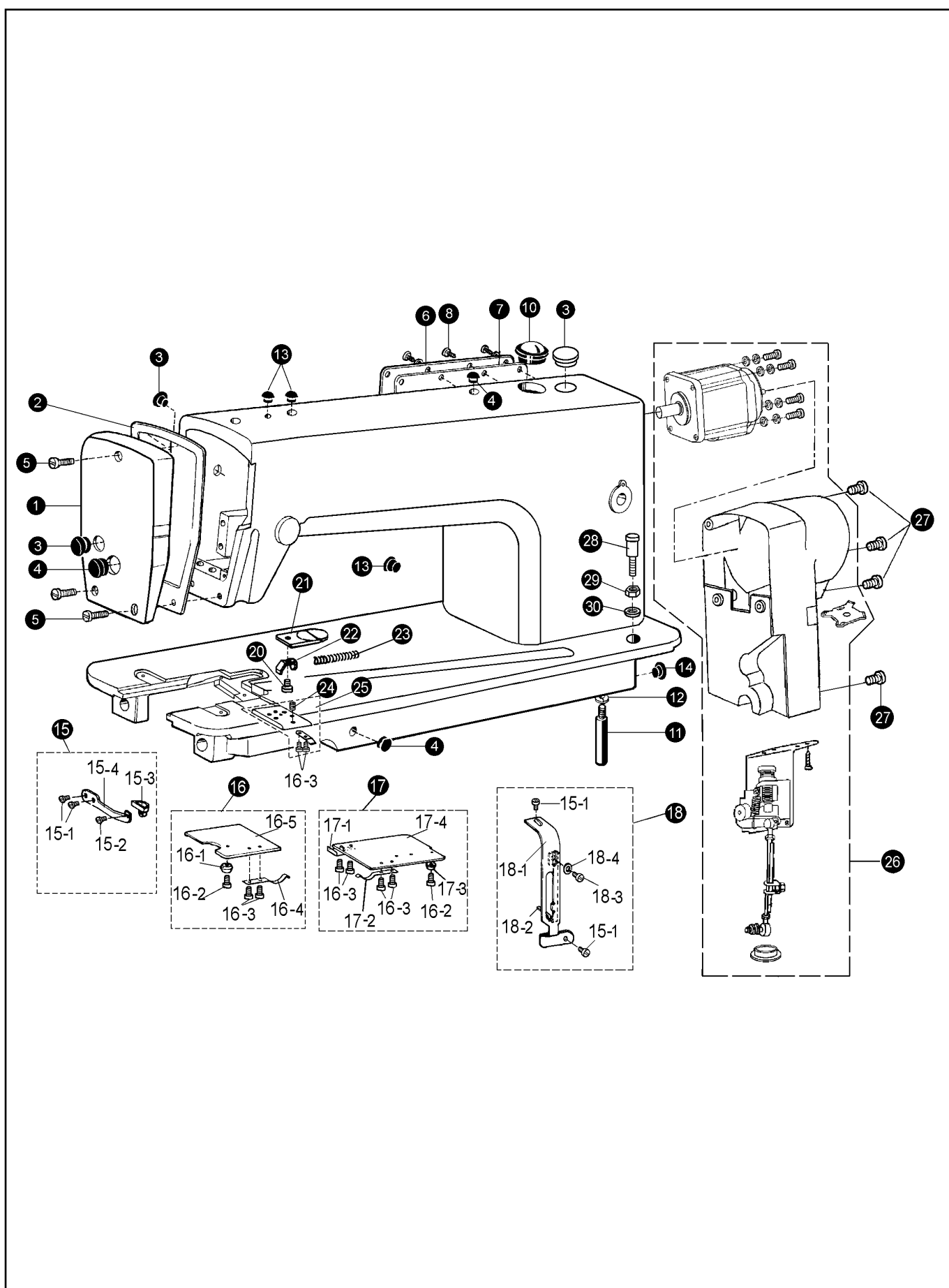

1. ARM BED AND ITS ACCESSORIES

No.	Ref.No.	Description	Qt.		
			- 1	- 2	- 3
1	238100001	Face plate	1	1	1
2	238100002	Face plate gasket	1	1	1
3	022130003- - V	Rubber plug	2	2	2
4	022130004- - V	Rubber plug	3	3	3
5	022100004	Screw	3	3	3
6	022140001- - W	Side plate	1	1	1
7	022140002	Gasket	1	1	1
8	022100006	Screw	8	8	8
10	022180000- - V	Oil check window assy	1	1	1
11	158100003	Bed support	2	2	2
12	S150601004	Washer (6)	2	2	2
13	022100015- - V	Rubber plug (¢ 8.8)	3	3	3
14	022100016- - 1	Rubber plug (¢ 27)	1	1	1
15	158H05000	Left spanner assy	1	1	1
15- 1	0585A0003	Screw	4	4	4
15- 2	028400068	Screw	1	1	1
15- 3	158140001	Left spanner	1	1	1
15- 4	158140002	Plate spring	1	1	1
16	158130000	Left slide plate	1	1	1
16- 1	158130003	Lockup collar	1	1	1
16- 2	028300034	Screw	2	2	2
16- 3	022170003	Screw for slide plate spring	8	8	8
16- 4	158130002	Plate spring	1	1	1
16- 5	158130001	Left slide plate	1	1	1
17	158120000	Right slide plate	1	1	1
17- 1	158120004	Plate spring	1	1	1
17- 2	158120003	Plate spring	1	1	1
17- 3	158120002	Lockup collar	1	1	1
17- 4	158120001	Right slide plate	1	1	1
18	158H05000	Thread take- up lever cover assy	1	1	1
18- 1	158H05001	Thread take- up lever cover	1	1	1
18- 2	158150002	Thread take- up tension plate	1	1	1
18- 3	022200004- - D	Screw (M5x18)	1	1	1
18- 4	008230003	Washer	1	1	1
20	158160002	Screw	1	1	1
21	158H00004	Right spanner	1	1	1
22	158160003	Spanner spring top plate	1	1	1
23	158100002	Plate spring	1	1	1
24	022230005	Screw	1	1	1
25	158170000	Folder assy	1	1	1
26	158H07000	Controller components	1	1	1
27	S150216033	Screw (M5x18)	5	5	5
28	158410001	Guard plate	1	1	1
29	S150503005	Nut	1	1	1
30	S150607004	Washer (6)	1	1	1

2. ARM SHAFT, NEEDLE BAR AND THREAD GUIDE MECHANISM (1)

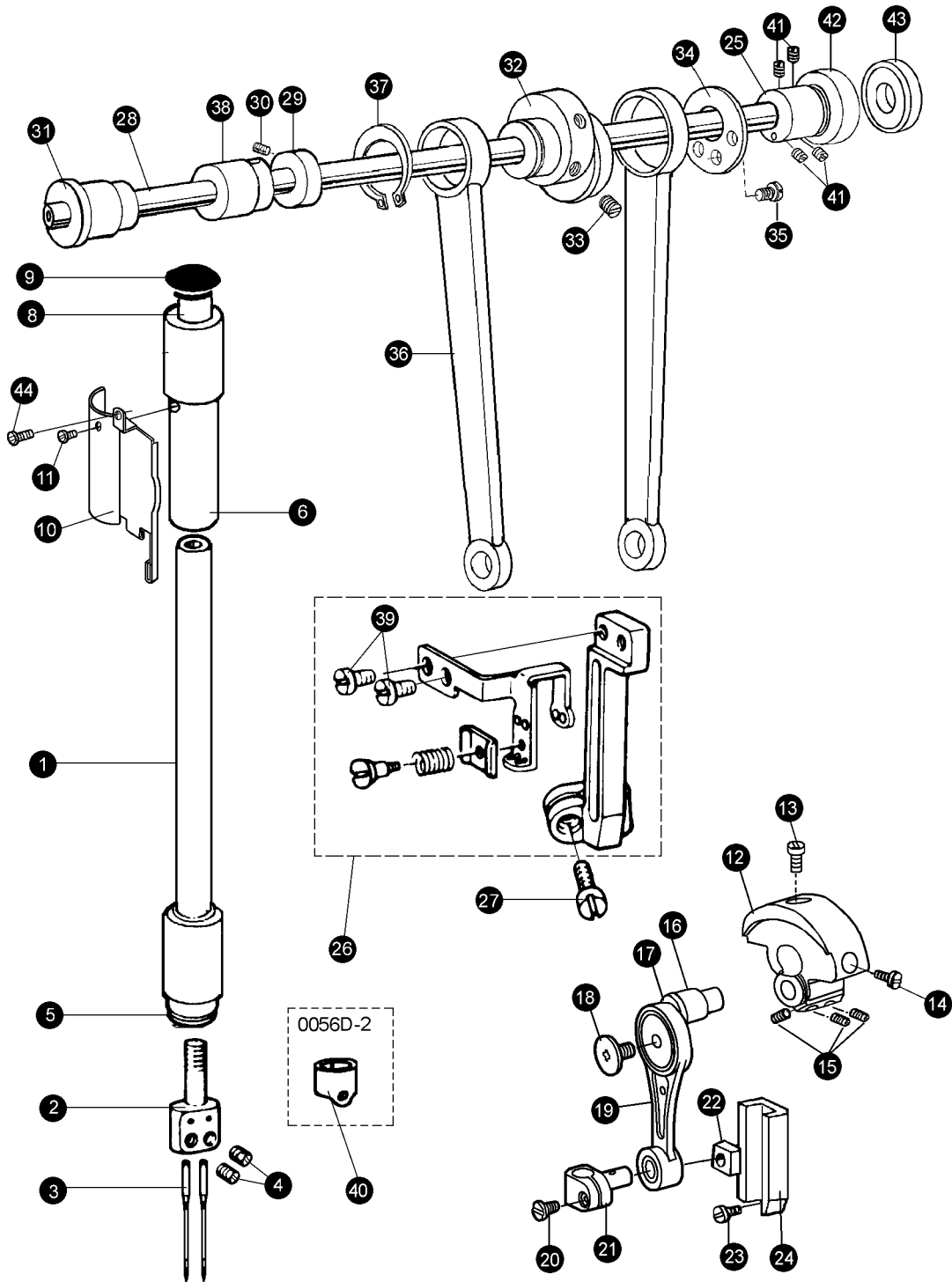

2. ARM SHAFT, NEEDLE BAR AND THREAD GUIDE MECHANISM (1)

No.	Ref.No.	Description	Qt.		
			- 1	- 2	- 3
1	158200001	Needle bar	1		1
	078200004	Needle bar		1	
2	158200002	Needle holder (6.4)	1		
	158A00003	Needle holder			1
3	158200012	Needle	2	1	2
4	022230005	Screw	2		2
	022200017	Screw		1	
5	158200003	Needle bar bushing (lower)	1	1	1
6	158200004	Needle bar bushing (upper)	1	1	1
8	022200010	Felt plug	1	1	1
9	022200011- - 1	Rubber plug	1	1	1
10	158H00006	Oil guard plate	1	1	1
11	028300038	Screw	1	1	1
12	238200002	Needle crank	1	1	1
13	022200007	Set screw	1	1	1
14	022200006	Screw	1	1	1
15	BX87459009	Screw (M6× 6)	4	4	7
16	158H00003	Washer	1	1	1
17	230100016	Thread take- up crank	1	1	1
18	BXF8688009	Screw (SM3.57- 40× 6L)	1	1	1
19	158H04100	Needle bar link assy	1	1	1
20	B960006009	Screw	1	1	1
21	BX85863009	Needle bar connecting	1	1	1
22	022200020	Slide block	1	1	1
23	022200019	Screw	2	2	2
24	238C00001	Slide block guide	1	1	1
25	257200002	Ball bearing	1	1	1
26	158H02000	Thread take- up lever assy	1	1	1
27	006200027	Screw	1	1	1
28	257200001	Arm shaft	1	1	1
29	022320001	Collar	1	1	1
30	022220003	Screw	2	2	1
31	022300003	Left bushing of arm shaft	1	1	1
32	03634	Feed eccentric cam	1	1	1
33	020300007	Screw	2	2	2
34	036300004	Guard plate	1	1	1
35	100600012	Screw	3	3	3
36	022343001	Feed lifting link	1	1	1
37	022342001	Stop collar	1	1	1
38	158200009	Middle bushing of arm shaft	1	1	1
39	022830004	Screw	2	2	2
40	048200004	Thread guide		1	
41	BX87459009	Screw (M6× 6)	2	2	2
42	S150801006	Bearing	1	1	1
43	238200004	Oil seal	1	1	1
44	0585A0003	Screw	1	1	1

3. ARM SHAFT, NEEDLE BAR AND THREAD GUIDE MECHANISM (2)

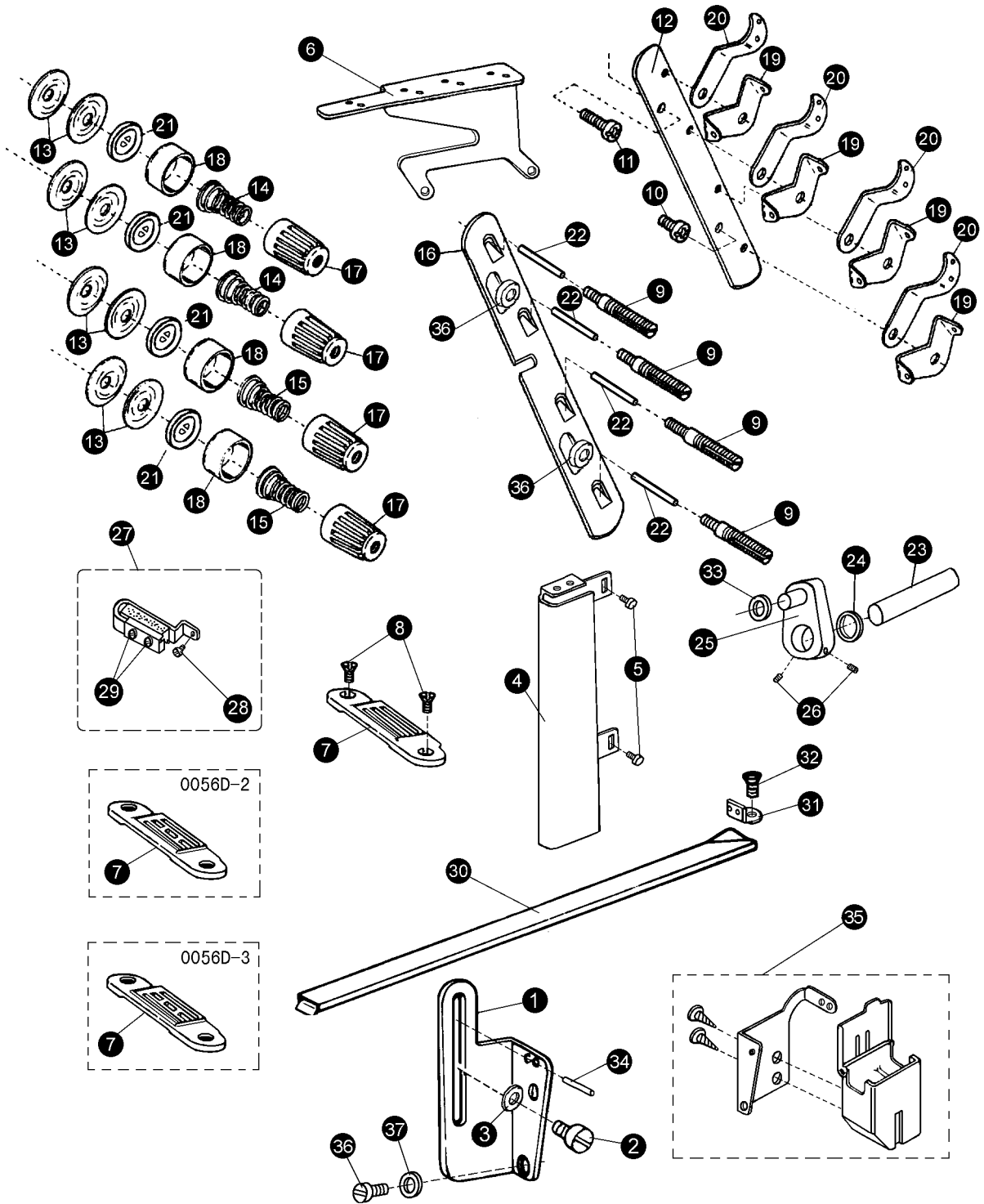

3. ARM SHAFT, NEEDLE BAR AND THREAD GUIDE MECHANISM (2)

No.	Ref.No.	Description	Qt.		
			- 1	- 2	- 3
1	158200006	Thread guide	1	1	1
2	022200004- - D	Screw	2	2	2
3	008230003	Washer	2	2	2
4	158200007	Bobbin guard plate	1	1	1
5	022200004- - D	Screw	2	2	2
6	158200008	Main thread guide holder	1	1	1
7	158200017	Throat plate (6.4)	1		
	158900009	Throat plate		1	
	158A00008	Throat plate			1
8	020100002	Screw of throat plate	2	2	2
9	158220006	Tension screw	4	4	4
10	158220009	Screw (short)	1	1	1
11	028100063	Screw (long)	1	1	1
12	158220001	Thread guide base	1	1	1
13	022160005	Tension disc	8	8	8
14	028283001	Tension spring	2	2	2
15	028283002	Tension spring	2	2	2
16	158220002	Thread tension plate	1	1	1
17	158H03001	Tension nut	4	4	4
18	158H03002	Tension base	4	4	4
19	116200016	Thread tension guide plate	4	4	4
20	116200015	Upper thread tension guide plate	4	4	4
21	022160004	Thread release plate	4	4	4
22	158220008	Pin	4	4	4
23	158H00001	Thread release shaft	1	1	1
24	158220007	O- ring	1	1	1
25	158200015	Tension crank	1	1	1
26	022100011	Screw	2	2	2
27	158240000	Thread tension assy (S)	1	1	1
28	022610004	Screw	1	1	1
29	028300034	Set screw	2	2	2
30	158H00005	Thread guide slot	1	1	1
31	158600024	Bed thread guide plate	1	1	1
32	020100002	Screw	1	1	1
33	158200016	Rubber washer	1	1	1
34	110100027	Pin	1	1	1
35	158830000	Silicon oil pot	1	1	1
36	158220003	Heel block	2	2	2

4. PRESSER BAR, VERTICAL SHAFT AND HOOK SHAFT MECHANISM

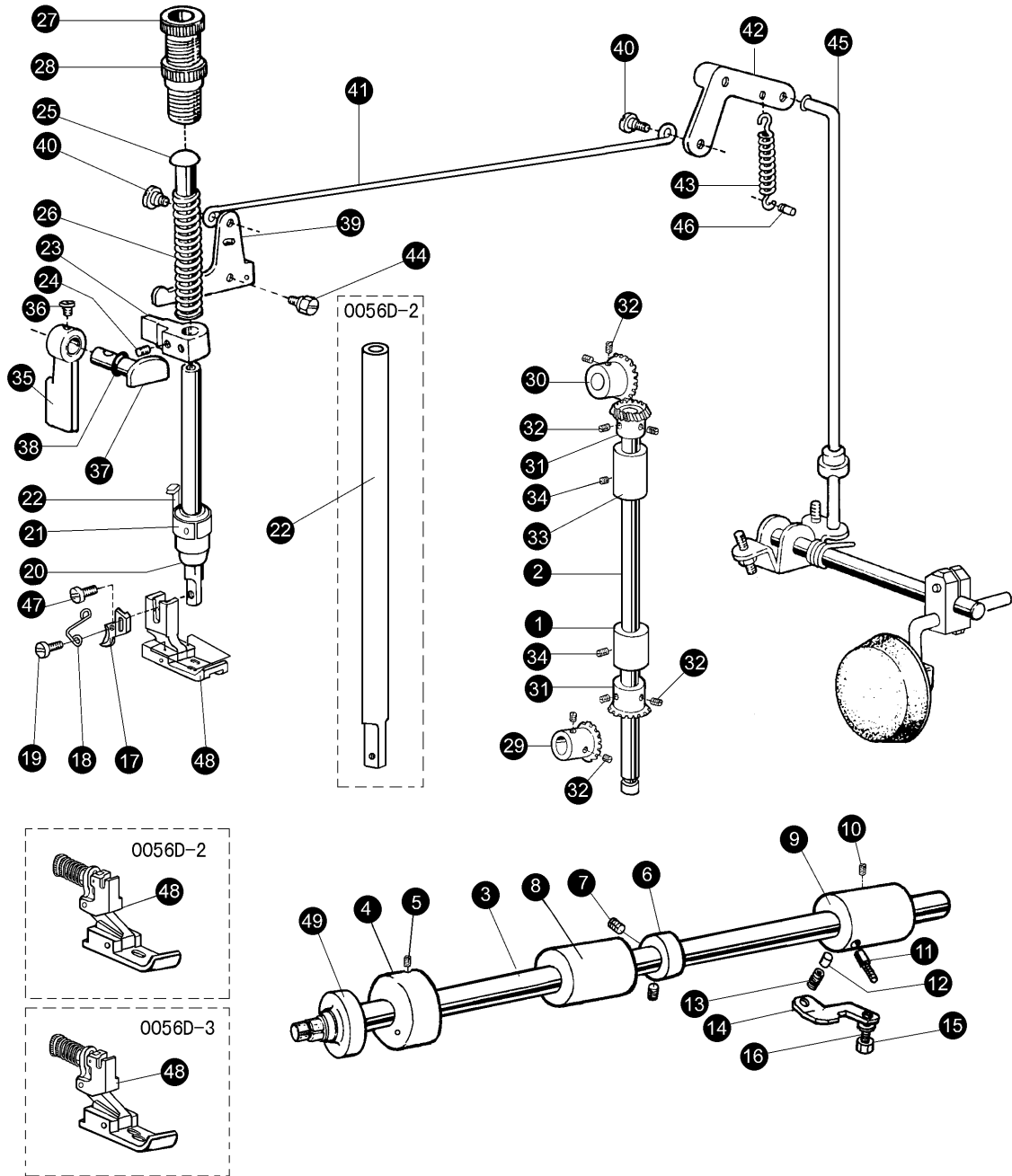

4. PRESSER BAR, VERTICAL SHAFT AND HOOK SHAFT MECHANISM

No.	Ref.No.	Description	Qt.		
			- 1	- 2	- 3
1	022300112	Vertical shaft bushing (lower)	1	1	1
2	158300002	Vertical shaft	1	1	1
3	158300003	Hook shaft	1	1	1
4	158300004	Bushing (left)	1	1	1
5	020300007	Screw	1	1	1
6	158300005	Thrust collar	1	1	1
7	022220003	Screw	2	2	2
8	158300006	Bushing (intermediate)	1	1	1
9	158300007	Bushing (right)	1	1	1
10	020700008	Screw	1	1	1
11	022430002	Oil pipe	1	1	1
12	036400015	Plunger	1	1	1
13	036400016	Plunger spring	1	1	1
14	158300008	Guide plate	1	1	1
15	022820001	Screw	1	1	1
16	S150601004	Spring washer	1	1	1
17	158300010	Cut knife	1	1	1
18	158300011	Guide plate	1	1	1
19	028300034	Screw	1	1	1
20	238400005	Bushing	1	1	1
21	238400006	Oil thread clamp	1	1	1
22- 1	158300012	Presser bar	1		
22- 2	158900006	Presser bar		1	1
23	158H00002	Presser bar lifting bracket	1	1	1
24	022200002	Screw	1	1	1
25	022700012	Presser bar guide	1	1	1
26	022700013	Presser spring	1	1	1
27	022750001- - W	Presser regulating thumb screw	1	1	1
28	022750002- - W	Presser regulating thumb nut	1	1	1
29	158340001	Bevel gear for hook shaft	1	1	1
30	022301N	Bevel gear for arm shaft	1	1	1
31	022302N	Bevel gear for vertical shaft (upper)	2	2	2
32	022220003	Screw	8	8	8
33	022300111	Vertical shaft bushing (upper)	1	1	1
34	020300007	Screw	2	2	2
35	022710001- - W	Presser foot lifter	1	1	1
36	B040600294	Screw	1	1	1
37	022700002	Presser foot cam	1	1	1
38	S150651010	Oil seal for presser foot cam	1	1	1
39	022721001	Knee lifter lever (left)	1	1	1
40	022720002	Hinge screw	2	2	2
41	238400002	Knee lifter lever	1	1	1
42	158310000	Knee lifter lever (right)	1	1	1
43	022730002	Spring for knee lifter lever (right)	1	1	1
44	022730004	Screw for knee lifter lever (right)	1	1	1
45	022730003	Knee lifter lever	1	1	1
46	022700008	Spring pin	1	1	1
47	022700015	Screw	1	1	1
48	158320000	Presser foot assy (6.4)	1		
	158910000	Presser foot assy		1	
	158A10000	Presser foot assy			1
49	158330000	Seal cover for hook shaft assy	1	1	1

5. STITCH LENGTH REGULATING MECHANISM

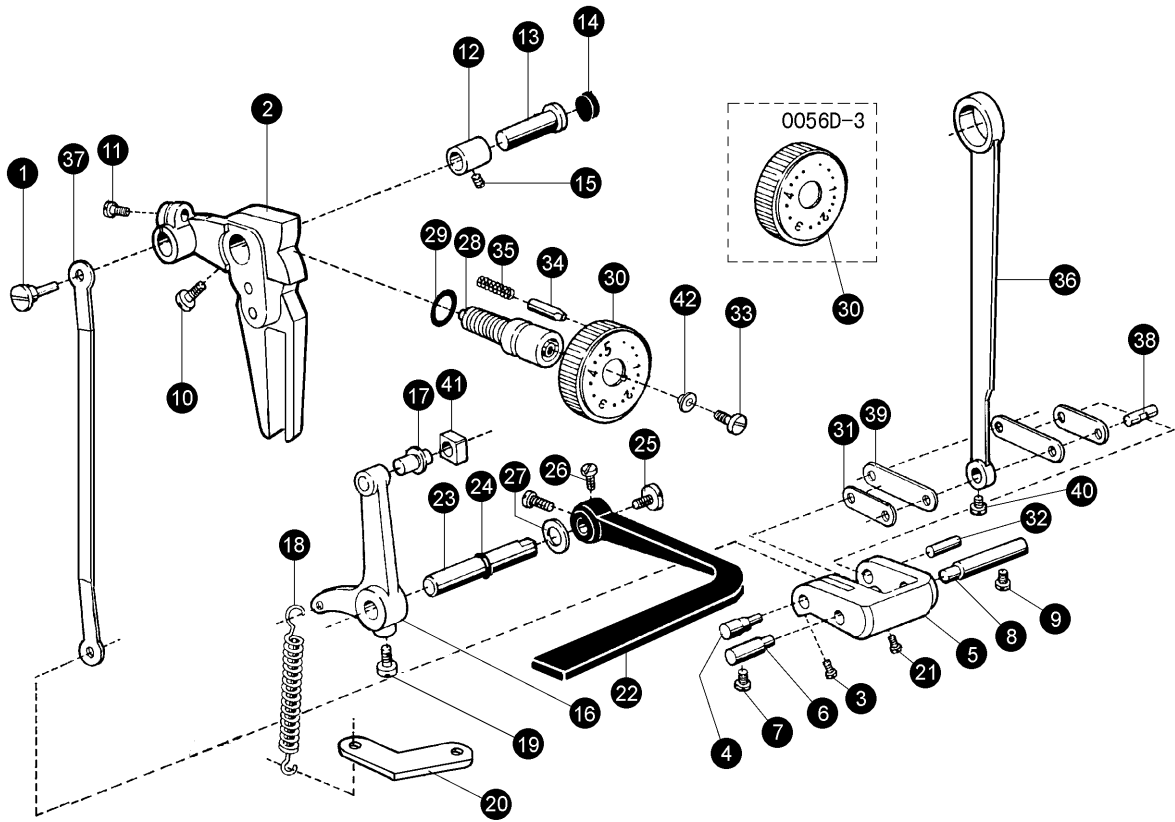

5. STITCH LENGTH REGULATING MECHANISM

No.	Ref.No.	Description	Qt.		
			- 1	- 2	- 3
1	036500001	Connecting stud	1	1	1
2	057500001	Feed regulator	1	1	1
3	036550008	Screw	1	1	1
4	036550009	Lever link eccentric shaft	1	1	1
5	036550010	Lever regulator	1	1	1
6	036580002	Pin (left)	1	1	1
7	022640003	Screw	1	1	1
8	036580001	Pin (right)	1	1	1
9	022640003	Screw	1	1	1
10	022510004	Screw of feed regulator	1	1	1
11	022640003	Screw	1	1	1
12	238300001	Feed regulator bushing	1	1	1
13	022500004	Feed regulator shaft	1	1	1
14	238300002	Rubber plug (¢ 16)	1	1	1
15	020300007	Set screw	1	1	1
16	022550001	Back tacking crank	1	1	1
17	022551	Slide block pin	1	1	1
18	057520001	Lever spring	1	1	1
19	022500013	Screw	1	1	1
20	158400002	Bracket for spring	1	1	1
21	036550007	Screw	1	1	1
22	124500004- - W	Backtacking lever	1	1	1
23	036531001	Backtacking lever shaft	1	1	1
24	S150651007	O- ring	1	1	1
25	022540003	Screw	1	1	1
26	022540004	Screw	2	2	2
27	022500011	Washer	1	1	1
28	238300003	Feed regulator screw	1	1	1
29	124510003	O- ring	1	1	1
30	238300006	Knob	1	1	
	238300005	Knob			1
31	036558001	Feed rock link	1	1	1
32	036550006	Pin	1	1	1
33	238300004	Screw	1	1	1
34	238300007	Stopper pin	1	1	1
35	022500009	Spring for stopper pin	1	1	1
36	036550002	Lever feed connecting rod	1	1	1
37	036550003	Feed regulator link	1	1	1
38	036400104	Sink shaft	1	1	1
39	036558002	Feed rock arm link	2	2	2
40	036550005	Screw	1	1	1
41	022551002	Crank slide block	1	1	1
42	036540004- - D	Bush for screw	1	1	1

6. FEEDING AND FEED LIFTING MECHANISM

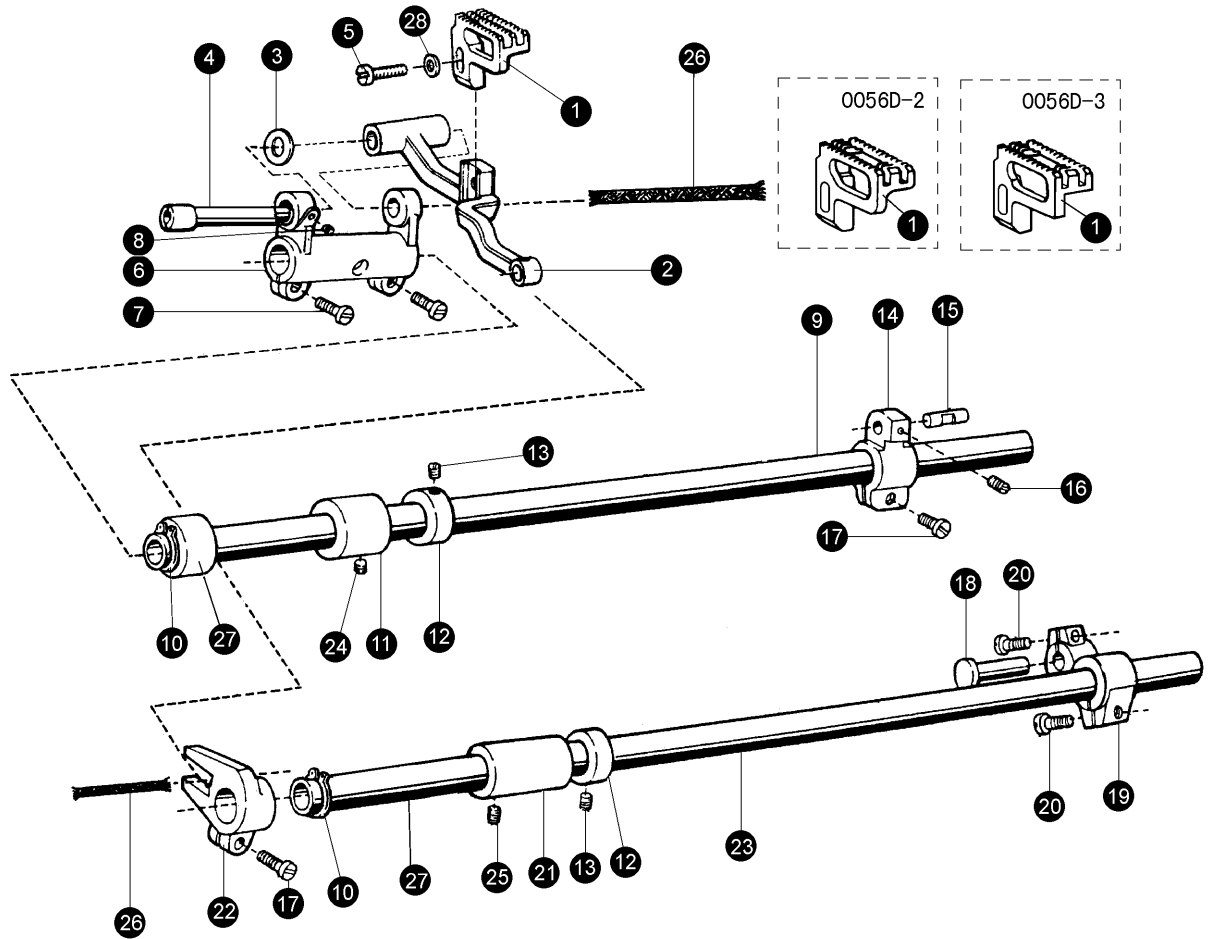

6. FEEDING AND FEED LIFTING MECHANISM

No.	Ref.No.	Description	Qt.		
			- 1	- 2	- 3
1	158510001	Feed dog (6.4、 5.6)	1		
	158900002	Feed dog		1	
	158A00002	Feed dog			1
2	158511000	Feed bar	1	1	1
3	022610006	Washer	1	1	1
4	158511002	Feed bracket shaft	1	1	1
5	S120203041	Screw	1	1	1
6	022611001	Feed rock bracket	1	1	1
7	158500006	Screw	2	2	1
8	022200019	Screw	1	1	2
9	158500001	Feed rock shaft	1	1	1
10	S150617006	Spring stop ring	2	2	1
11	124600001	Feed rock shaft bushing	1	1	2
12	022620001	Collar	2	2	1
13	006200021	Screw	4	4	2
14	036400003	Feed rock shaft crank (right)	1	1	4
15	036400204	Pin	1	1	1
16	036550005	Screw	1	1	1
17	022640003	Screw	2	2	1
18	022600007	Hinge pin	1	1	2
19	036400017	Feed lifting crank (right)	1	1	1
20	022600016	Screw	2	2	1
21	158500004	Bushing	1	1	2
22	036484001	Forked feed lifting	1	1	1
23	158500003	Feed lifting rock shaft	1	1	1
24	020700008	Screw	1	1	1
25	020300007	Set screw	1	1	1
26		Oil wick	1	1	1
27	158500005	Feed rock shaft bushing (left)	1	1	1
28	008230003	Washer	1	1	1

7. LOOPER MECHANISM (1)

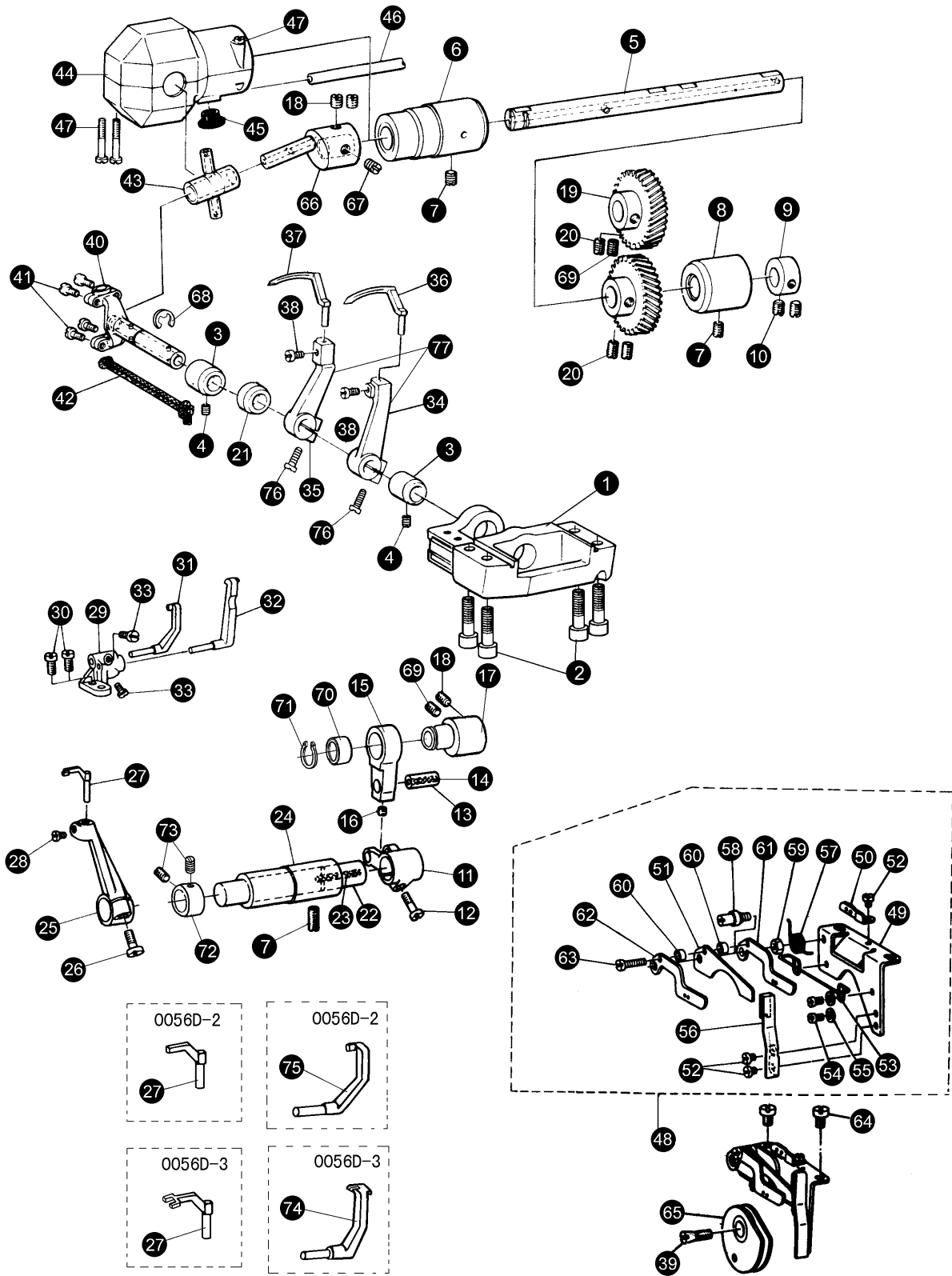

7. LOOPER MECHANISM (1)

No.	Ref.No.	Description	Qt.		
			- 1	- 2	- 3
1	158600001	Looper holder	1	1	1
2	S150209058	Screw (M6× 20)	4	4	4
3	158600002	Bushing	2	2	2
4	022100011	Screw	2	2	2
5	158600003	Looper shaft	1	1	1
6	158600004	Looper shaft bushing (front)	1	1	1
7	020300007	Screw	3	3	3
8	158300006	Looper shaft bushing (rear)	1	1	1
9	158300005	Collar	1	1	1
10	022220003	Screw	2	2	2
11	158600005	Forked protecting crank	1	1	1
12	022640003	Screw	1	1	1
13	158600006	Pin	1	1	1
14		Yarn (¢ 3× 35)	1	1	1
15	158600007	Protecting crank	1	1	1
16	028700004	Screw	1	1	1
17	158600008	Thread guard cam	1	1	1
18	058211002	Screw	3	3	3
19	158670000	Rotation gear assy	1	1	1
20	058211002	Screw	3	3	3
21	158900005	Heel block		1	
22	1158600011	Protecting shaft	1	1	1
23		Yarn (¢ 4× 200)	1	1	1
24	158600012	Bushing	1	1	1
25	158600013	Driving thread guard frame	1	1	1
26	S150299002	Screw	1	1	1
27	158600014	Driving thread guard bar (6.4、 5.6)	1		
	158A00004	Driving thread guard bar			1
	158900003	Driving thread guard bar		2	
28	036550007	Screw	1	1	1
29	158600015	Thread guard plate	1	1	1
30	0585A0003	Screw	2	2	2
31	158600016	Left thread guard bar	1		
32	158600017	Right thread guard bar	1		
33	B994787009	Screw	2	1	1
34	158600018	Left looper holder	1	1	1
35	158600019	Right looper holder	1		1

7. LOOPER MECHANISM (2)

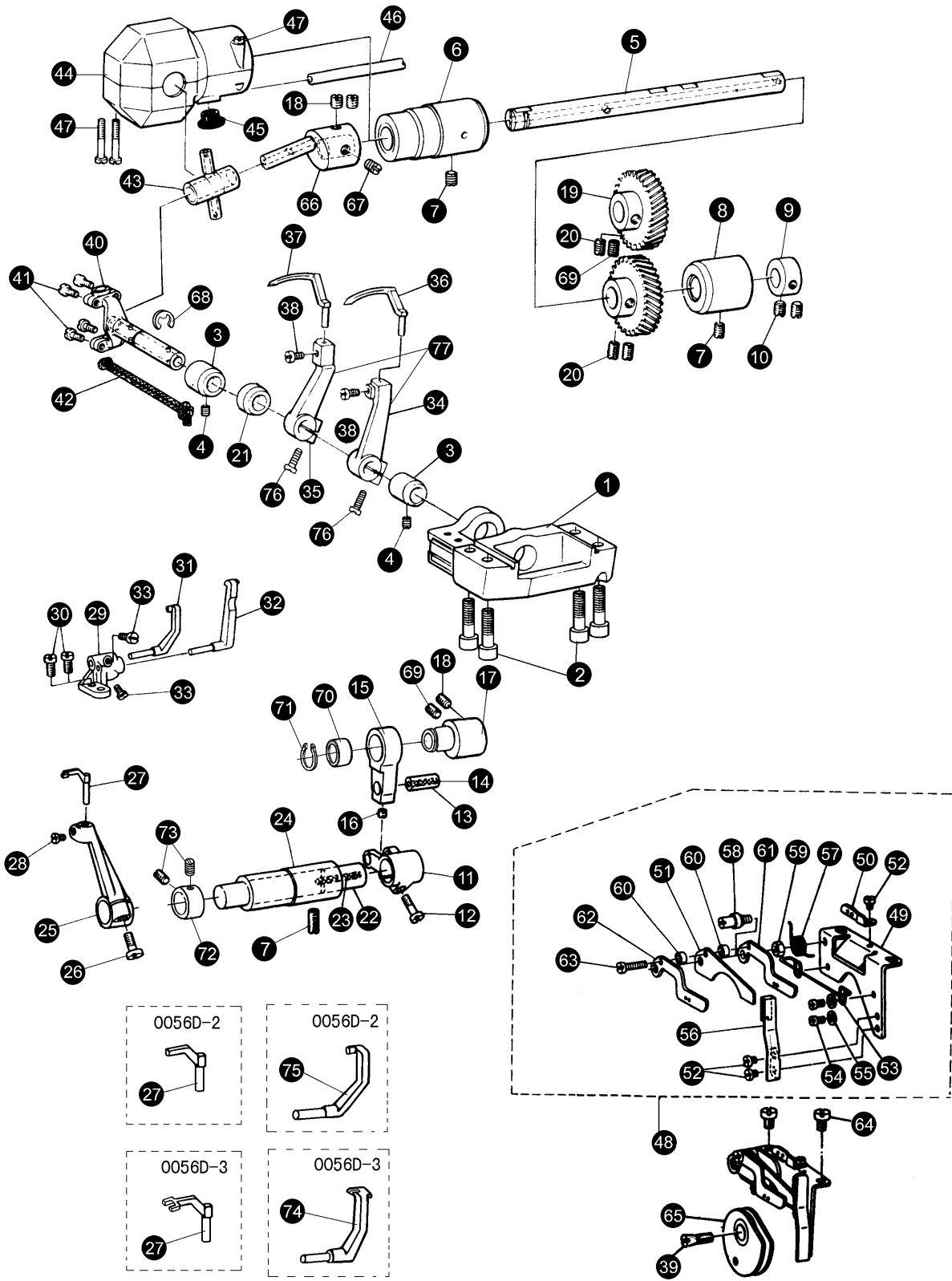

7. LOOPER MECHANISM (2)

No.	Ref.No.	Description	Qt.		
			- 1	- 2	- 3
36	158600020	Left looper	1	1	1
37	158600021	Right looper	1		1
38	058312002	Screw of looper	2	1	2
39	158600022	Screw of cam	1	1	1
40	158611001	Looper rocker shaft assy	1	1	1
41	028200056	Screw	4	4	4
42		Yarn ($\text{C } 4 \times 140$)	1	1	1
43	158612000	Cross assy	1	1	1
44	158630000	Looper crank cover assy	1	1	1
45	022130004- - 1	Rubber plug	1	1	1
46	158630003	Oil pipe ($\text{C } 3/5 \times 82$)	1	1	1
47	158630004	Screw	3	3	3
48	158640000	Thread take- up cam assy	1	1	1
49	158640001	Thread take- up cam	1	1	1
50	158640002	Thread guide plate (S)	1	1	1
51	158640003	Thread guide bracket	1	1	1
52	158160002	Screw	3	3	3
53	158640004	Thread guide spring	1	1	1
54	028400068	Screw	2	2	2
55	S150607007	Washer	2	2	2
56	158640005	Screw for cam holder	1	1	1
57	158640006	Screw for cam holder	1	1	1
58	158640007	Screw	1	1	1
59	158640008	Nut	1	1	1
60	158640009	Washer	2	2	2
61	158640010	Right thread guide plate	1	1	1
62	158640011	Left thread guide plate	1	1	1
63	022800004	Screw	1	1	1
64	022200004	Screw	2	2	2
65	158650000	Cam holder assy	1	1	1
66	158660000	Looper crank assy	1	1	1
67	158660002	Eccentric screw	1	1	1
68	158600025	Thrust collar	1	1	1
69	B900859009	Screw	2	2	2
70	S150866020	Needle bearing	1	1	1
71	S150649006	Retaining ring (GB894.1- 86)	1	1	1
72	158600026	Collar	1	1	1
73	022220003	Screw	2	2	2
74	158A00005	Fixed thread guard bar			1
75	158900004	Fixed thread guard bar		1	
76	S150299002	Screw M5x14(GB70- 85)	2	1	2
77	S150299027	Screw M4x4	2	1	2

8. LUBRICATION MECHANISM

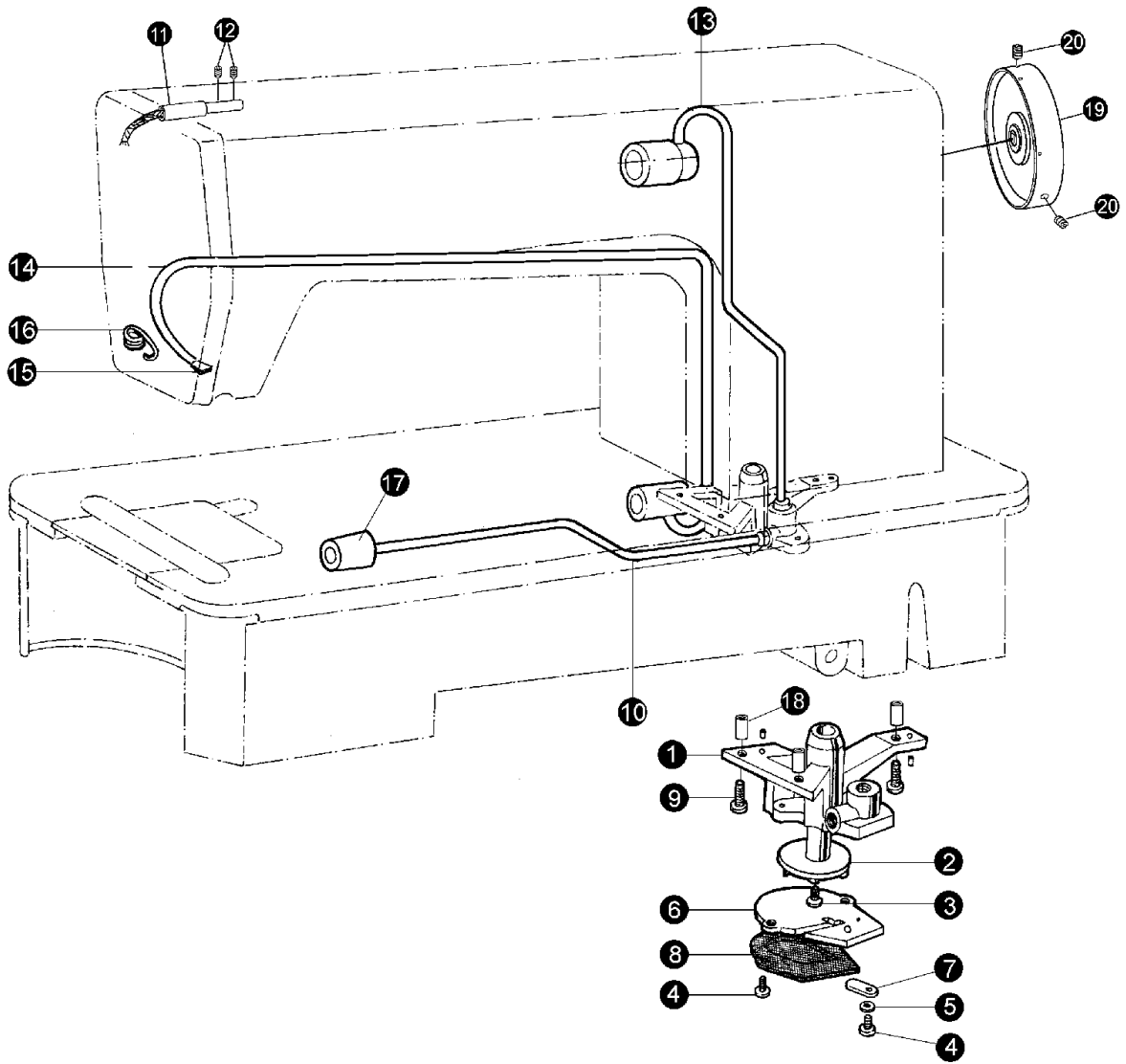

8. LUBRICATION MECHANISM

No.	Ref.No.	Description	Qt.		
			- 1	- 2	- 3
1	158700004	Oil pump body	1	1	1
2	022800002	Oil pump impeller	1	1	1
3	022800003	Screw	1	1	1
4	022800004	Screw	3	3	3
5	S150601003	Spring washer	1	1	1
6	158700004	Oil pump filting plate	1	1	1
7	158700007	Oil adjusting plate	1	1	1
8	158730000	Oil pump screen assy	1	1	1
9	158700006	Screw	3	3	3
10	158710000	Oil pipe for hook shaft	1	1	1
11	158H00009	Oil braid filting plate	1	1	1
12	022200002	Screw	2	2	2
13	158720000	Oil pipe for arm shaft	1	1	1
14	022800014	Oil returning pipe	1	1	1
15	022800015	Filter felt for returning pipe	1	1	1
16	036A00002	Spring for oil felt	1	1	1
17	158700001	Oil pipe connecting	1	1	1
18	158700003	Oil pump body cushion	3	3	3
19	238710001	Balance wheel	1	1	1
20	S150215001	Screw M5x8	2	2	2
21	257700001	Motor	1	1	1
22	B084050974	Washer plain	4	4	4
23	B082050864	Washer	4	4	4
24	B048509294	Screw (M5x18)	4	4	4

9. OIL RESERVOIR AND OTHER ACCESSORIES

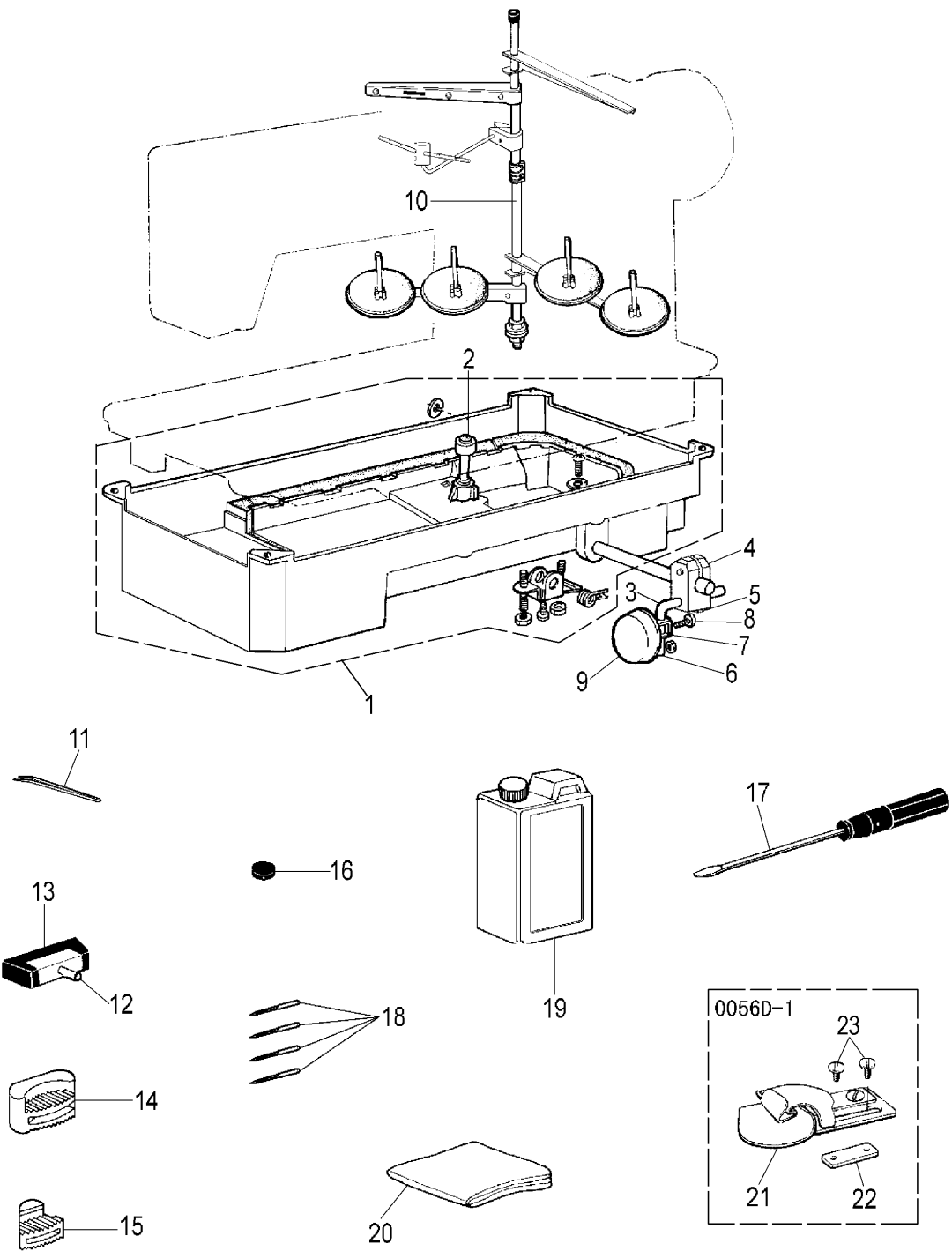

9. OIL RESERVOIR AND OTHER ACCESSORIES

No.	Ref.No.	Description	Qt.		
			- 1	- 2	- 3
1	158810001	Oil reservoir	1	1	1
2	022910002	Oil drain screw	1	1	1
3	022910003	Washer	1	1	1
4	158810002	Gasket for oil reservoir (L)	2	2	2
5	158810003	Gasket for oil reservoir (S)	1	1	1
6	158810004	Gasket for oil reservoir (M)	1	1	1
7	022910006	Hinge pin for knee lifter lever	1	1	1
8	GB896- 86	Thrust collar	1	1	1
9	022910007	Back spring for knee lifter	1	1	1
10	022910008	Knee lifter stop bracket	1	1	1
11	022900036	Screw	1	1	1
12	022910009	Adjusting screw	2	2	2
13	022910010	Lock nut	1	1	1
14	238C14000	Speed governor assy	1	1	1
15	158810005	Knee lifter lifting rod	1	1	1
16	W210105018	Knee lifter plate crank	1	1	1
17	W210105029	Knee lifter plate crank joint	1	1	1
18	S150106003	Screw	2	2	2
19	022920009	Knee lifter plate crank joint	1	1	1
20	W210105004	Bracket for knee lifter plate	1	1	1
21	S150106005	Screw	1	1	1
22	022920008- - V	Gasket for knee lifter plate	1	1	1
23	238C15000	Rod assy	1	1	1
24	W060401013	Tweezer	1	1	1
25	088900101- - W	Spool stand	1		1
	006F00030- - W	Spool stand		1	
26	02299	Hinge of machine head	2	2	2
27	022960002	Hinge socket of machine head	2	2	2
28	022900009	Rubber cap (L)	2	2	2
29	022900010	Rubber cap (S)	2	2	2
30	W060302010	Oil pot	1	1	1
31	W060404014	Magnet	1	1	1
32	W060401017	Screw driver (L)	1	1	1
33	158200012	Needle TVx7 14#	1	1	1
35	W060302087	Oil can	1	1	1
36	W060302058	Machine head cover	1	1	1
38	158820000	1/4" folder	1		
40	W050101039	Screw (M5× 12)	4	4	4
41	238C00006	Magnet assy	1	1	1

OPTIONAL PARTS LIST

No.	Ref.No.	Description	Qt.		
			- 1	- 2	- 3
1- 1	158B70005	Left slide plate (12.7mm)	1		
1- 2	158B50006	Right slide plate (7.9、 9.5mm)	1		
1- 3	158B70006	Right slide plate (12.7mm)	1		
2- 1	158B10003	Needle holder (3.2)	1		
2- 2	158B20002	Needle holder (4.0)	1		
2- 3	158B30002	Needle holder (4.8)	1		
2- 4	158B40002	Needle holder (5.6)	1		
2- 5	158B50003	Needle holder (7.9)	1		
2- 6	158B60002	Needle holder (9.5)	1		
2- 7	158B70003	Needle holder (12.7)	1		
3- 1	158B10001	Throat plate (3.2)	1		
3- 2	158B20001	Throat plate (4.0)	1		
3- 3	158B30001	Throat plate (4.8)	1		
3- 4	158B40001	Throat plate (5.6)	1		
3- 5	158B50005	Throat plate (7.9)	1		
3- 6	158B60004	Throat plate (9.5)	1		
3- 7	158B70007	Throat plate (12.7)	1		
4- 1	158B11000	Presser foot assy (3.2)	1		
4- 2	158B21000	Presser foot assy (4.0)	1		
4- 3	158B31000	Presser foot assy (4.8)	1		
4- 4	158B41000	Presser foot assy (5.6)	1		
4- 5	158B51000	Presser foot assy (7.9)	1		
4- 6	158B61000	Presser foot assy (9.5)	1		
4- 7	158B71000	Presser foot assy (12.7)	1		
6- 1	158B10004	Feed dog (3.2、 4.0)	1		
6- 2	158B30003	Feed dog (4.8)	1		
6- 3	158B50004	Feed dog (7.9)	1		
6- 4	158B60003	Feed dog (9.5)	1		
6- 5	158B70004	Feed dog (12.7)	1		
7- 1	158B10002	Driving thread guard bar (3.2、 4.0、 4.8)	1		
7- 2	158B50002	Driving thread guard bar (7.9、 9.5)	1		
7- 3	158B70002	Driving thread guard bar (12.7)	1		
9- 1	158B12000	1/8" folder	1		
9- 2	158B22000	5/32" folder	1		
9- 3	158B32000	3/16" folder	1		
9- 4	158B42000	7/32" folder	1		
9- 5	158B52000	5/16" folder	1		
9- 6	158B62000	3/8" folder	1		

Special- use parts for 0056D- 4

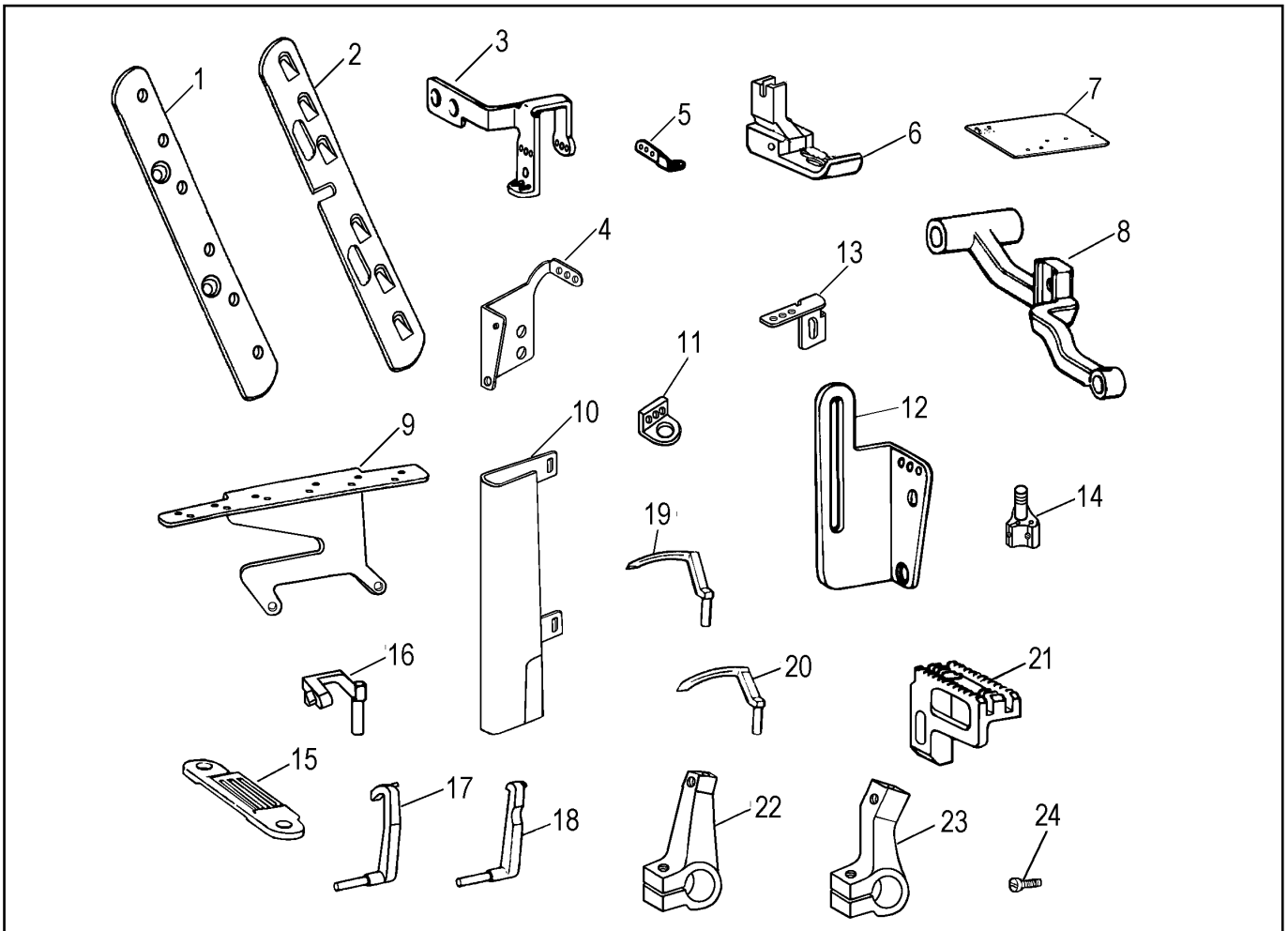

Special- use parts for 0056D- 4

No.	Ref.No.	Description	Qt.		No.	Ref.No.	Description	Qt.	
			4A	4B				4A	4B
1	158C10000	Main thread guide base	1	1	15	158C00007	Needle plate (6.4)	1	
2	158C10002	Thread release plate	1	1		158G00002	Needle plate		1
3	158C20000	Thread take- up lever	1	1	16	158C00008	Driving thread guard frame	1	
4	158C30000	Bracket for silicone oil cup	1	1		158G00005	Driving thread guard frame		1
5	158C40000	Thread guide plate (S)	1	1	17	158C00009	Left protecting bar	1	
6	158C50001	Presser foot assy	1			158G00006	Left protecting bar		1
	158G10000	Presser foot assy		1	18	158C00010	Right protecting bar	1	1
7	158C60001	Right slide plate	1	1	19	158C00013	Right looper	1	1
8	158C70001	Feed bar	1	1	20	158C00014	Left looper	2	2
9	158C00001	Main thread guide holder	1	1	21	158C00015	Feed dog	1	
10	158C00002	Bobbin guard plate	1	1		158G00004	Feed dog		1
11	158C00003	Bed thread guider plate	1	1	22	158E00001	Left looper holder	2	2
12	158C00004	Thread guide	1	1	23	158E00002	Right looper holder	1	1
13	158C00005	Thread guide holder	1	1	24	158E00003	Screw	3	3
14	158C00006	Needle holder	1						
	158G00001	Needle holder		1					

1.Pre-start checks

1. The machine shall not be started running until the completion of oiling.
2. The rotating direction of the balance wheel, when the machine is started running, shall be in counter clockwise one.(View from the right side of the balance wheel.) A warning shall be given in advance against making the machine run while balance wheel turning clockwise.
3. The machine shall be under operation at less than 2,500 s.p.m, for the first month.
4. Check power source, voltage and phase number to see whether they are in accordance with the ratings on the name plate of the motor to be used.

2.Operating instructions

- 1.Do not put your hands under the lower part of the needle when the machine is running.
- 2.Do not put your fingers into the thread take-up lever cover when the machine is running
- 3.Only when the machine stops can you turn the balance wheel by hand.
- 4.After the motor switch being turned off, due to inertia ,the motor will continue to rotate for a while,Be careful not to have the machine tilted unless it stops.
- 5.Do not make anything such as finger and hair near the balance wheel, V-belt and the motor.
- 6.Do not start running the machine during mounting or replacing the belt cover, finger guard, etc.

3.Specification

Stitch type	Chain stitch
Speed	Max.4,000 s.p.m.
Needle	TVx7 9#-21# or GKx2 9#-21#
Stitch length	1.6-5mm (0056D -3, 1.6-4mm)
Stroke of needle bar	31 .8mm
Gaugas of double-row	1/8" 5/32" 3/16" 7/32" 1/4" 5/16" 3/8" 1/2"chain stitch
Thread take-up type	Needle bar thread take up type
Looper	Separately adjustable type, for the range of 1/8" to1/2"
Needle guard	Oscillating type and rigid type
Light clearance of knee liffter	10mm
Oil supply	Impeller-type pump
Lubricating oil	18# sewing machine oil

4.Oil filling(Fig1.and 2)

1. Replenish the oil reservoir with oil and make the oil surface near to the mark "H".
2. If the oil amount level is under the mark "L", replenish the oil reservoir with oil in time.
3. The normal condition of lubrication is that the oil shall spray onto the oil sight. The amount of oil spraying onto the oil sight is not at all proportional to the total amount of oil in the oil reservoir. There is nothing to worry about.
4. When filling oil, loosen the oil draining screw, drain off the remaining oil in the oil reservoir completely.After tighten the oil draining screw, fill the oil reservoir with fresh oil.
5. When a new model or those standing idle for long time are to be operated, presser foot shall be lifted and run idle for about ten minutes.

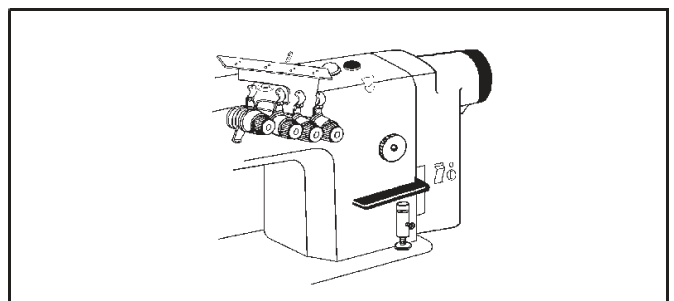
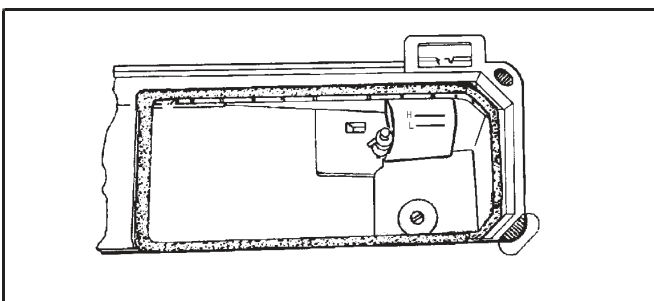

5. Threading (Fig3. and 4)

Threading bobbin thread first. To make bobbin thread go through the eye of the needle in the order as shown in.

1. Make the bobbin thread go through the tension guide plate, go through the two holes when thread of harder twist fiber is used or feed gauge is wider than usual.
2. Pull the spring toward the operator, as shown in Fig.4 and part A will rise upwards.
3. When threading the looper, the thread shall be made go through the eye of the needle with a tweezer as shown in Fig.4 and 50mm of remaining thread be pulled out.

To thread the needle thread, raise the needle bar to the upper end of its stroke, lead the thread go through the eyes of the needle in the order as shown in Fig.3

1. To make thread go through the eye of the needle outwards. (View from the operator's side)
2. To pull out 100mm of the remaining thread after needle thread going through the eyes of the needle.

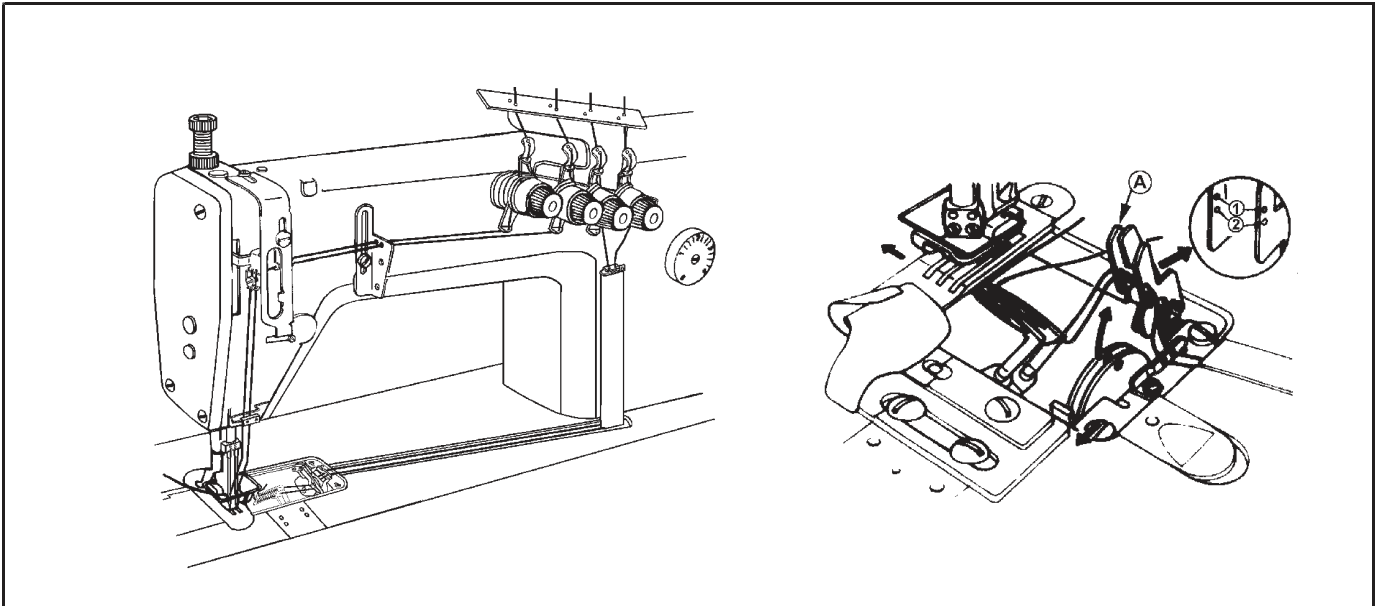

6. Adjustment of the thread tension (Fig5. and 6)

To adjust needle thread tension in accordance with sewing working condition, we can adjust needle thread tension by tension spring. Turn the tension nut clockwise to increase the tension; turn counter-clockwise to decrease the tension.

The relation between the needle thread and the bobbin thread as shown in (Fig6) depicts the forming of chain stitch.

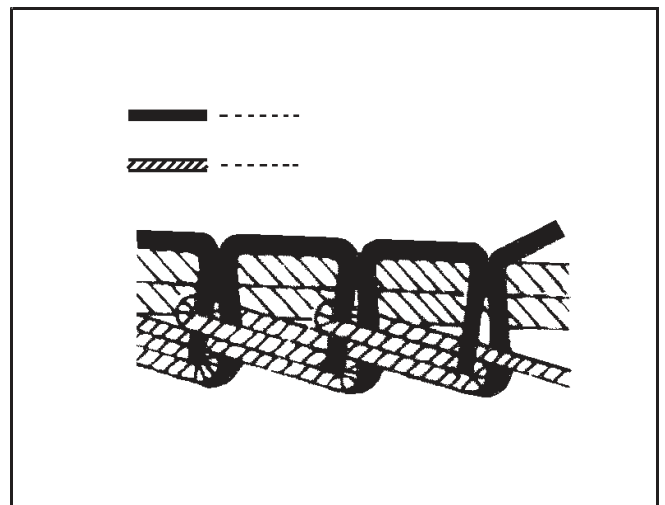
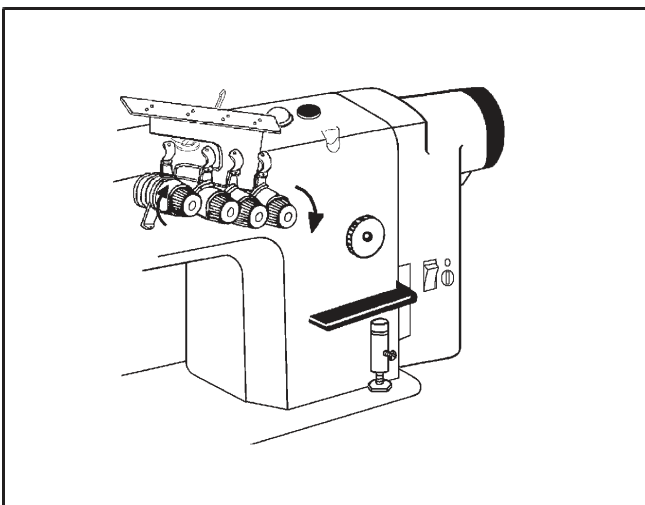

7. Adjustment of pressure on presser foot (Fig.7 and 8)

Turn pressure regulating thumb screw clockwise to increase the pressure; turn pressure regulating thumb screw counter-clockwise to decrease the pressure. For general fabric the standard height of pressure regulating thumb screw is about 27–30mm.

The presser bar lifter shall be turned either leftward or rightward in order to keep the presser foot under the condition of lifting position. (Fig. 8)

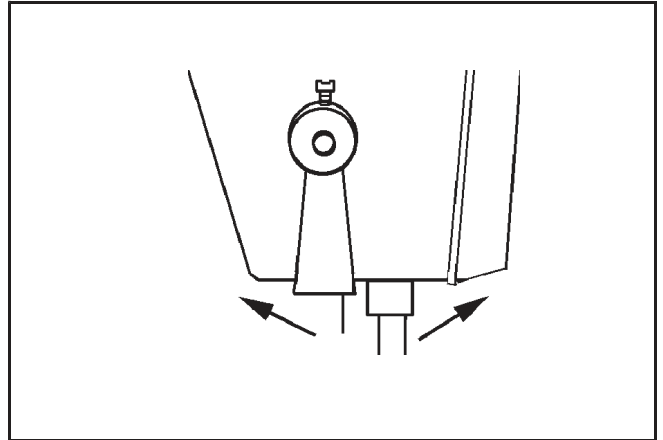
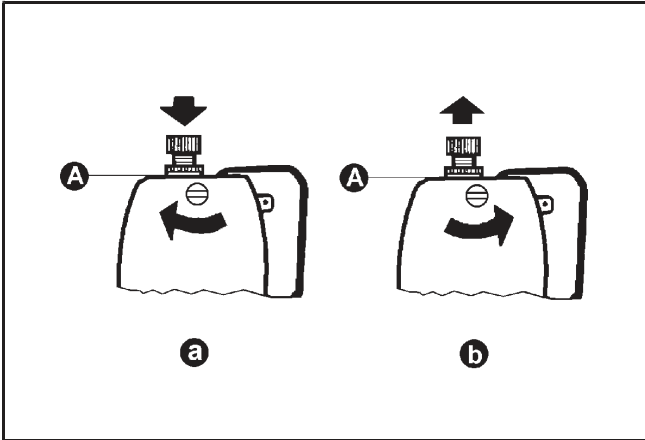

8. To adjust stitch length (Fig. 9)

1. Turn stitch length dial to the desired number. The calibration is shown in millimeter (mm)

2. If you intend to decrease the stitch length, press down the reverse feed lever while turning the feed regulating dial.

3. Max. stitch length is 5 (0056D–3,4mm); Min. stitch length is 1.4mm.

4. This version of stitch is suitable for beginning and end seaming or bar tacking.

Caution: The machine can not make reverse stitching.

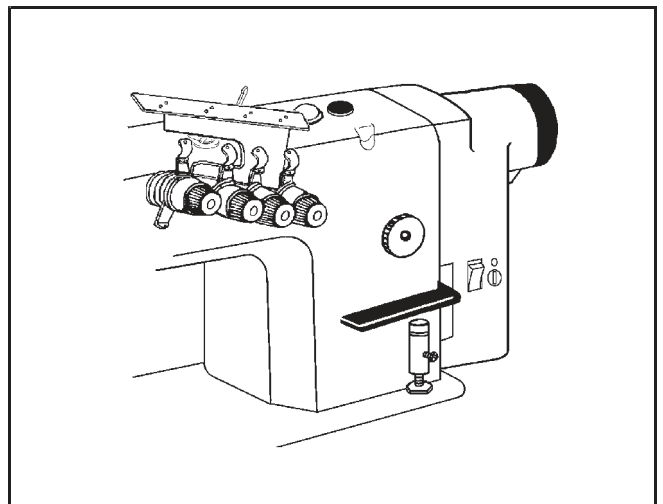

9. Setting-up of the needle (Fig.10 and 11)

The direction of the needle eye should be in that direction, as shown in Fig. 10. Needle types to be desired fall within the range of #9 to #21 of TV 7 or GK 2. Oil tank shall be custom-made when thread of chemical fibre is used; silicone oil can be placed like that, as indicated in Fig.11.

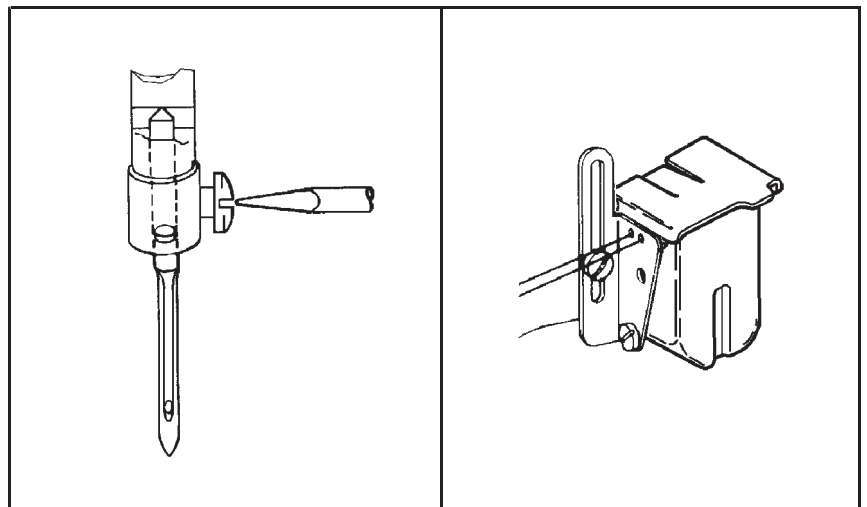

10.Adjustment of the height of the presser bar(Fig.12)

For the requirements of either replacing the presser foot, or changing the height and angle of presser foot the following shall be observed.

- 1.take off the rubber plug from the face plate.
- 2.Loosen the presser bar guide bracket set screw.
- 3.After adjusting, retighten the screw.

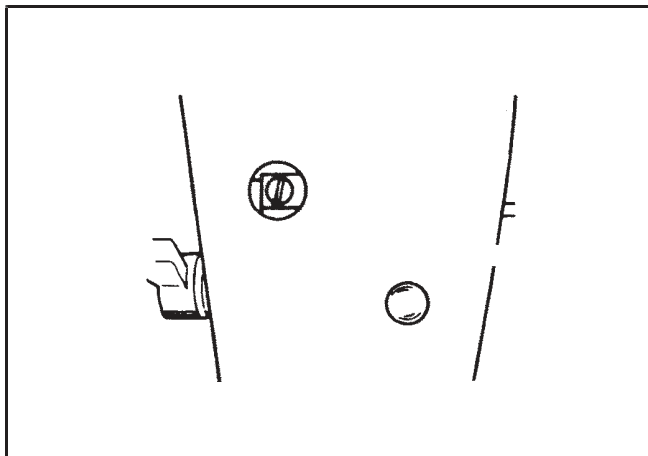

11.Adjustment of the height of the feed dog(Fig.13 and 14)

Loosen the set screw ,as shown in Fig. 14, the angle of the feed dog can be adjusted to the specified one of standard version, A version and B version. The Max. height of the projection from feed dog is 0.8mm and is adjustable by the adjusting of screw 1 as shown in fig. 13.

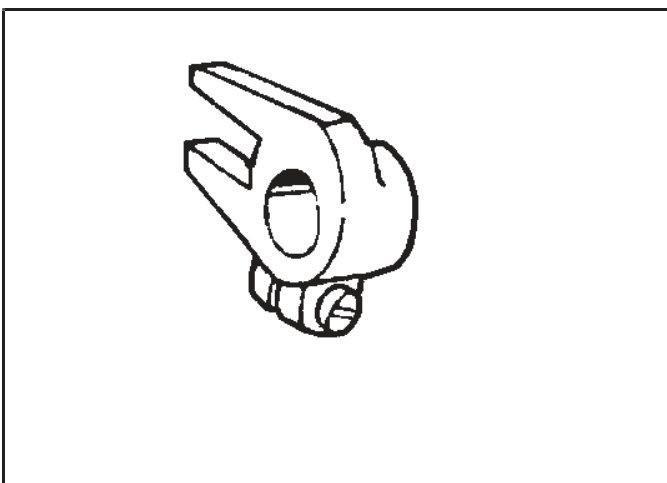
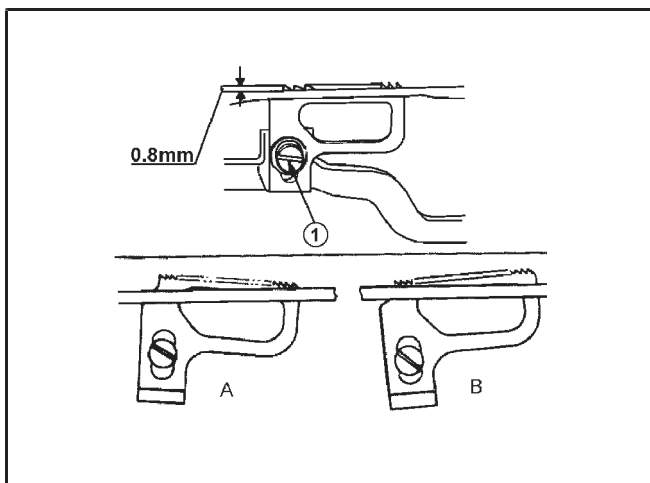

12.The timing of feed dog and needle(Fig. 15)

When the point of needle lowering down to the location of 3mm from the upper surface of the throat plate, the feed dog is right below the upper surface of the throat plate,viz.the running of feed dog being well regulated in relation to motion of needle.

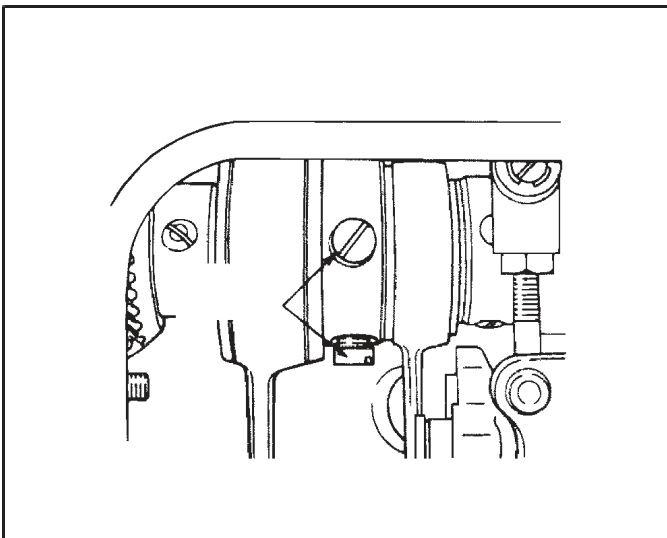

13.Adjustment of the height of needle bar(Fig.16)

The distance from the point of needle to the upper surface of the throat plate should be 11 mm, as the needle bar at the top dead centre.

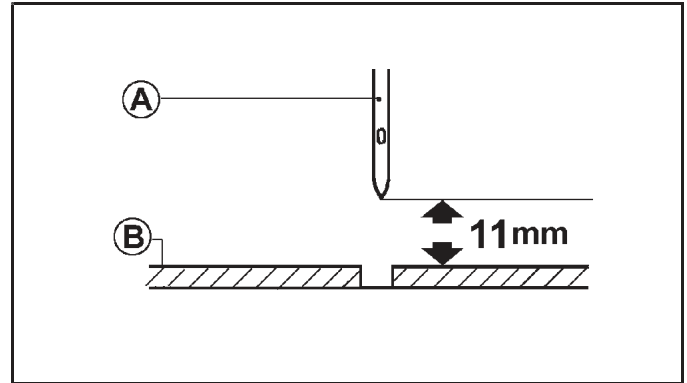

14.Adjustment of the needle and looper(Fig.17 and 18)

Adjustment of forward & backward motion of the looper: The dimension of part B of the looper in an elliptic motion can be measured by adjusting proceeding as follows (refer to Fig. 17). The Max. dimension of part B is usually 3.7mm, which is suitable for all kinds of needle.

1. Take off the rubber plug on the crank cover of the looper (refer to Fig. 18).
2. Turn the balance wheel by hand.
3. First loosen set screw and positioning screw, and then adjust marked screw.
4. The dimension of part B will be increased when turn clockwise the adjustable screw on which punch mark is printed.
5. Tighten set screw and positioning screw.

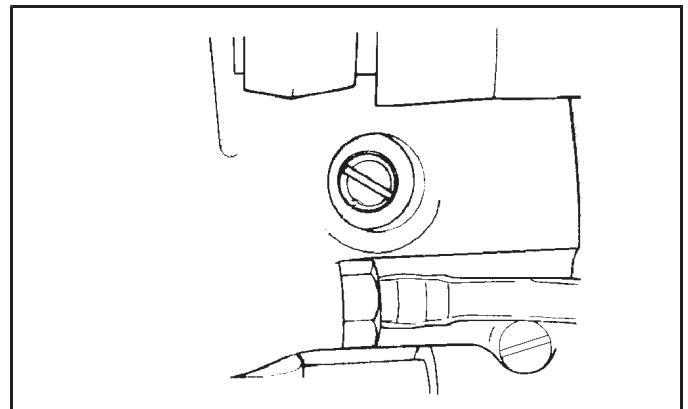
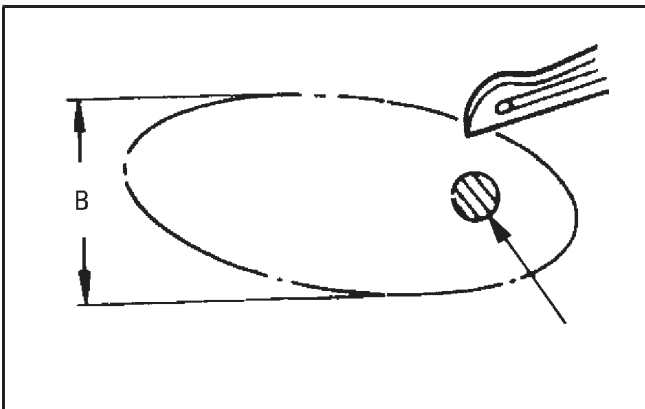

15.The timing of looper in reference to needle(Fig.19)

The looper shall be moved backward to the rightmost position while the needle is at the bottom dead centre; loosen the screw on the gear and make timing adjustment of the looper in relation to the needle.

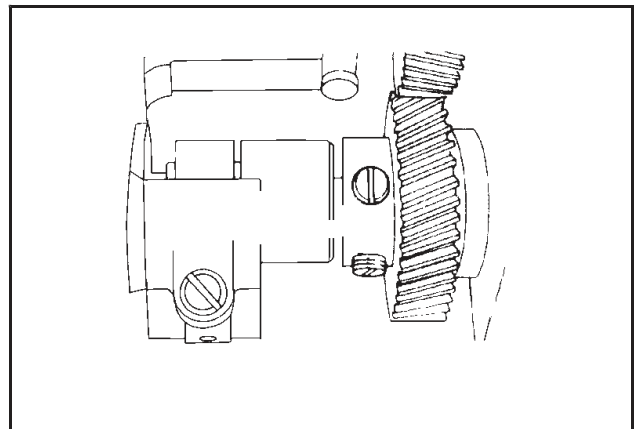

16. Threading-guiding amount of the looper (Fig.20)

1. the standard value of the vertical distance of the point of the looper away from the upper end of the eye of the needle is 2mm.
2. The value of the stroke moved backward by the looper is about 3.0mm.
3. The relation between the eye of the needle and the eye of the looper is indicated in Fig.17 (the left looper and the right one can be separately adjusted)

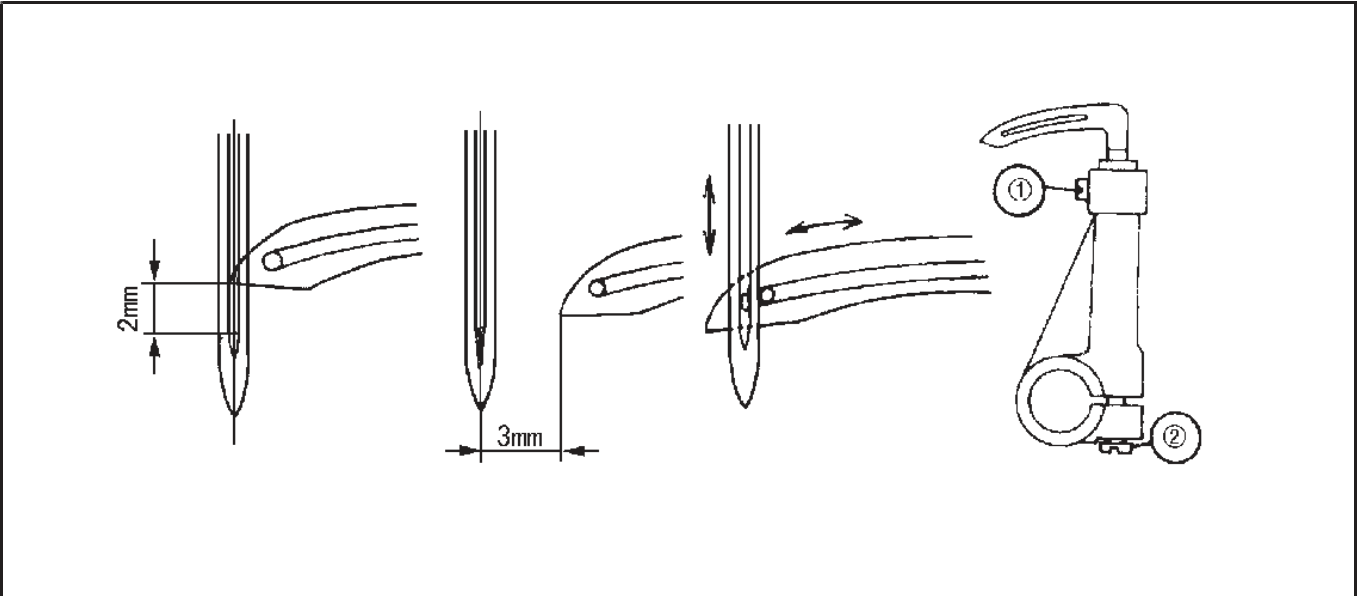

17. The clearance of looper and needle

After adjusting the needle guard, there should be a certain clearance between the needle and the looper. The needle should not touch the point of the looper when it is pressed down softly. If the clearance is narrower than usual, the side of the needle and the point of the looper are apt to incur breakage due to they impact each other.

18. The timing of needle guard (Fig.21)

the timing of the needle guard depends on the condition of the plane on the rock shaft of the looper when no.1 screw (shown in Fig.21) has been screwed into this rock shaft.

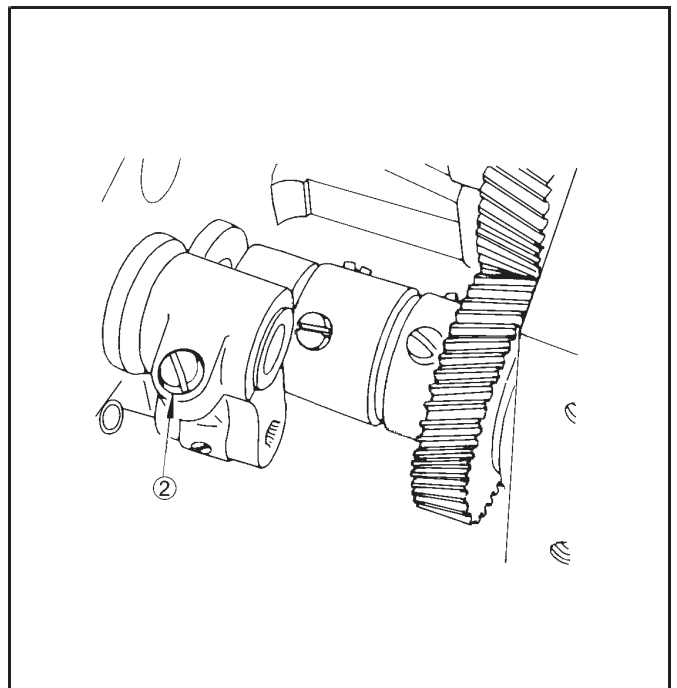

19. Position of needle guard (Fig. 22)

Oscillating the needle guard to make the needle tip contact with needle gauge slightly, it is recommended that the height adjustment shall not fall within the range of the fixing needle guard; the adjustment can be made by loosening screws 1 and 2.

The relation between fixing needle guard and the driving needle guard is as represented in Fig.22; the clearance from the needle falls within the range of 0.1 to 0.2mm.

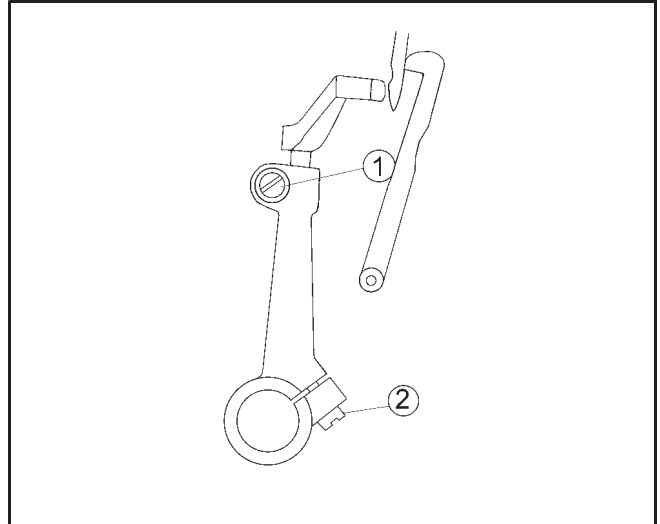

20. Looper thread take-up cam (Fig. 23)

Its position can be seen as shown in Fig.23. when the needle bar is at the top dead center, the angle between the planes of the cam and the steel wire is 18–20 degrees. First loosen screw B, and then make adjustment, finally tighten the screw firmly.

Pay close attention to the following: the needle tip shall entirely come into the thread loop of the looper when the bobbin thread rejecting from the projecting part of the cam.

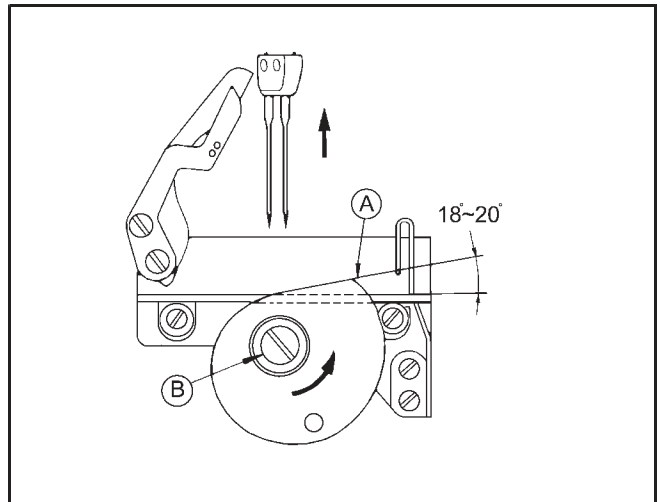

21. The position of the take-up thread tension lever (Fig. 24)

Make the take-up thread tension lever cover the face plate when the needle bar is at the bottom dead centre; in such way the loop of the needle thread is to become bigger when the needle thread is hooked.

In addition to the foregoing there is a function that it tightens the needle thread loop. The take-up thread tension lever usually reduces to the lowest point when a thread thinner than normal is used.

The improper-position of the frame thread

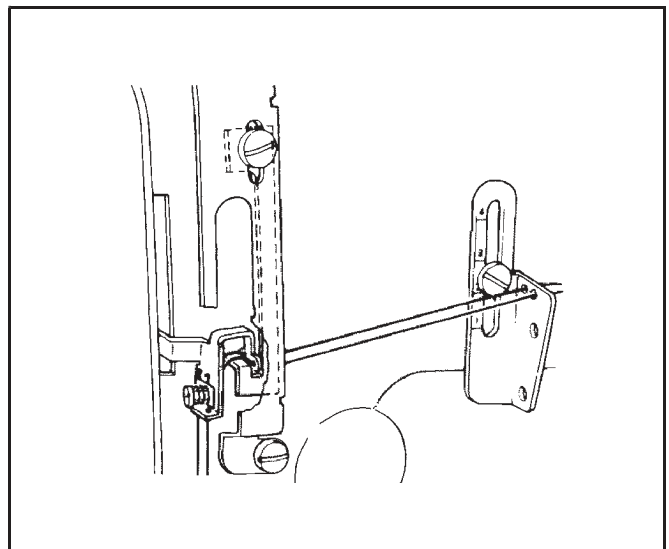

22. Frame thread eyelet(Fig. 25)

eyelet may be the cause of skipping stitch.

The following locations are generally regarded as criteria (Fig. 25)

Cotton thread 80#–50#	Graduation marked on the frame thread eyelet 2–3
Cotton thread 30#–50#	Graduation marked on the frame thread eyelet 3–4
Thread of chemical fibre 80#–50#	Graduation marked on the frame thread eyelet 1–2
Thread of chemical fibre 30#–20#	Graduation marked on the frame thread eyelet 2–3

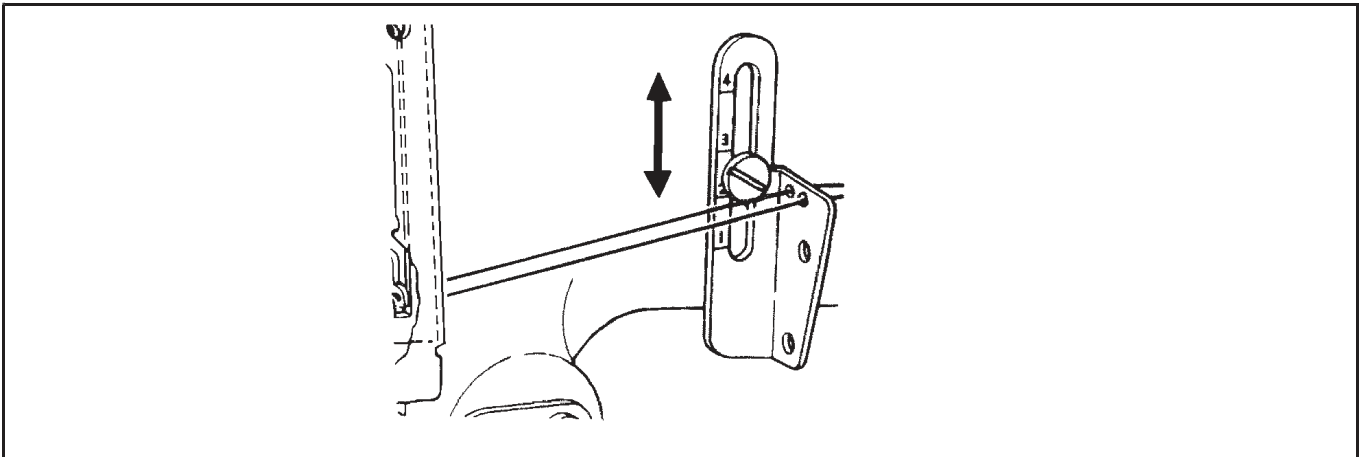

23. Replacement of throat plate(Fig. 26)

The standard size of the throat plate in parts book, which is stipulated by the manufactory, is 1/4", equivalent to 6.4mm.

The replacement of the following components is usually needed when changing the gauge of double-row thread stitch.

1. needle clamp. 2. Presser foot. 3. Throat plate. 4. feed dog. 5. Rear driving needle guard. 6. folder. The left and right loopers within the range of the sizes from 1/8" to 1/2" are interchangeable. In addition to the aforesaid, the replacement of left and right slide plate and cam cover shall be made when the width of throat plate is on the increase.

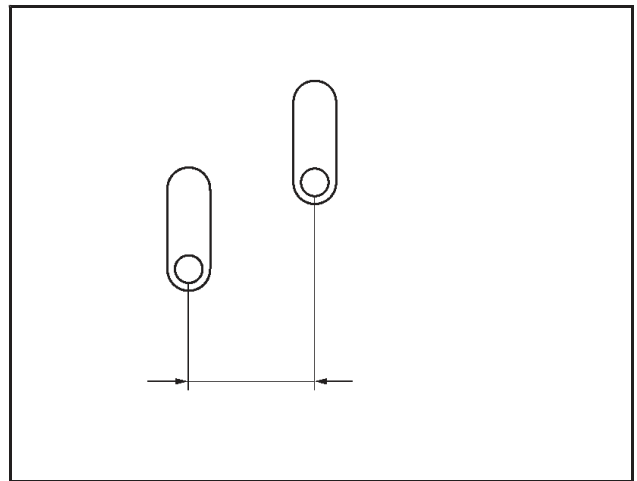

24. Maintenance of the machine

The following shall be adhered to in order to keep the machine in good working condition:

1. Daily checking.

(1) The oil shall spray onto the oil sight when the machine is running.

(2) Stop the machine when abnormal sound is heard during the operation of the machine.

2. Locations to be checked once a week.

(1) To take off throat plate, left and right slide plate to clean dust of the slot feed dog with a brush.

(2) To turn over the head to rid of oil stain and dust of both the oil filter screen on the oil pump and the interior of the oil reservoir.

(3) Loosen drain hole screw and take it off, drain all the dirty oil from the oil reservoir and reoil it.

(4) Oil level must be above the lowest oil-level-indicating line marker "L".

(5) The black powder, adhering to the magnet in the oil reservoir shall be wiped with sponge cloth.

25.Common breakdowns and measures of trouble shooting

Thread breakage	<ol style="list-style-type: none"> 1.Poor thread quality 2.Thread being too thick 3.Fusing thread due to high temperature of needle caused by machine's operation at high speed 4.Tension being too higher 5.Breakage of needle ,looper, throat plate and needle guard at the location of thread guide 6.Failure to adjust thread amount 	<ol style="list-style-type: none"> 1.Quality thread to be used 2.Replacement to be made by an appropriate thread 3.Silicone oil to be used or speed to be reduced 4.The tension nut be loosened 5.First grinding with oil stone and then polishing 6.Adjusting the take-up thread tension lever
Skipping stitch	<ol style="list-style-type: none"> 1.Skipping stitch of needle thread(leaking of two stitches due to the looper's failure to hook the needle thread) 	<ol style="list-style-type: none"> 1.Adjusting thread-hooking amount of looper 2.Adjusting clearance between looper and needle 3.The timing of needle in reference to looper 4.Adjusting the take-up thread tension lever on thread amount changing conditions 5.Adjusting the frame thread eyelet 6.Checking whether the mounting position of the needle is proper or not 7.To see if the location of needle guard is an appropriate way and the timing of it is well regulated in relation to another 8.To see if the needle thread Threading is in proper way
Skipping stitch	<ol style="list-style-type: none"> 2.Skipping stitch of bobbin thread(leaking of one stitch, needle failure to enter the looper eyelet) 	<ol style="list-style-type: none"> 1.Reference to the above cases 1and2,as to skipping stitch of the needle thread 2.To see if the timing of bobbin thread cam has been well regulated 3.Increasing the tension of bobbin thread a bit 4.To see if the threading of bobbin thread is in a correct way
Skipping stitch	<ol style="list-style-type: none"> 3.Skipping stitch when thread of chemical fibre being in use 	<ol style="list-style-type: none"> 1.Using silicon oil 2.Reducing speed 3.Using needle for thread of chemical fibre
Skipping stitch	<ol style="list-style-type: none"> 4.Skipping stitch when thread of polyester fiber being in use 	<ol style="list-style-type: none"> 1.Reducing speed 2.Silicone oil to be used
Twisted stitches	<ol style="list-style-type: none"> 1.Needle thread tension being too low 2.Bobbin thread tension being too low 3.Sewing thread being too thick 4.Improper position of the frame thread eyelet 5.Improper position of take - up thread tension lever 6.Throat plate 	<ol style="list-style-type: none"> 1.Tightening tension not of needle thread 2.Tightening tension not of bobbin thread 3.Large size needle to be used 4.Readjusting it to a proper position 5.Readjusting its position in an appropriate way 6.The eyelet of throat plate to be used being bigger than normal one
Breakage of needle	<ol style="list-style-type: none"> 1.Needle being bent 2.The problem of the timing of feed dog and needle 3.Wrong setting - up of the presser foot 4.The problem of the needle guard remaining unsolved 5.Needle thread tension being too high 6.Needle being too thick 	<ol style="list-style-type: none"> 1.Needle to be replaced by another proper size one 2.Readjusting the timing to feed dog in reference to the needle 3.To make both center of the hole of the presser foot and the center of the eyelet of the throat plate be in line with that of the eye of the needle 4.The position and the timing of the needle guard to be taken into account 5.Relaxing needle thread 6.Appropriate needle to be used
Puckering	<ol style="list-style-type: none"> 1.Threading tension being too high 2.The problem of the timing of the bobbin thread cam for thread guiding failing to be solved 3.Improper polish of the parts on thread guide 4.The force on the presser foot being too big 	<ol style="list-style-type: none"> 1.Decreasing thread tension ,esp.tension of bobbin thread 2.Readjusting of the very cam to solve the timing problem 3.Burnishing all the thread guide parts 4.Turning counter - clockwise the pressure - regulation screw

- Besides adjusting stitch, please lay people don't debug or maintain.
- Parts are subject to changes in design without prior notice.

XI'AN TYPICAL INDUSTRIES CO.,LTD.

Add: No.335 Taibai South Road,
Xi'an, P.R. China-710068
Tel: +86-29-88279091 88279150
Fax: +86-29-88249715 88245215
E-mail: typical@chinatypical.com
[Http://www.chinatypical.com](http://www.chinatypical.com)
[Http://www.chinatypical.com](http://www.chinatypical.com)